

**Operating manual
Maintenance manual
Spare parts**

Refrigerating air dryer

DRYPOINT® RA HT 20-350 NA

Dear Customer,

thank you for choosing our product. In order to get the best performances out of this product, please read this manual carefully.

To avoid incorrect operation of the equipment and possible physical risk to the operator, please read and strictly follow the instructions contained in this manual.

Note, these instructions are in addition to the safety rules that apply in the country where the dryer is installed. Before packing for shipment each **DRYPOINT RA HT NA** series refrigerated air dryer undergoes a rigorous test to ensure the absence of any manufacturing faults and to demonstrate that the device can perform all the functions for which it has been designed.

Once the dryer has been properly installed according to the instructions in this manual, it will be ready for use without any further adjustment. The operation is fully automatic, and the maintenance is limited to few controls and some cleaning operations, as detailed in the following chapters.

This manual must be maintained available in any moment for future references and it has to be intended as inherent part of the relevant dryer.

Due to the continuous technical evolution, we reserve the right to introduce any necessary change without giving previous notice.

Should you experience any trouble, or for further information, please do not hesitate to contact us.

DATA NAMEPLATE

The data nameplate is located on the back of the dryer and shows all the primary data of the machine. Upon installation, fill in the table on the previous page with all the data shown on the data nameplate. This data should always be referred to when calling the manufacturer or distributor. The removal or alteration of the data nameplate will void the warranty rights.

Model	⇒
Product key	⇒
Serial n°	⇒
Nominal Flow Rate	⇒
Working pressure PS min/max	⇒
Inlet temperature TS max	⇒
Ambient Temp.	⇒
Refrigerant	⇒
Refrig. Design Pres. HP/LP	⇒
Power supply	⇒
Electric Nominal Power	⇒
Fuse Max.	⇒

DRYPOINT RA	
Product key: Produktschlüssel:	<input type="text"/>
Serial n° / year of building: Serienr. / Baujahr:	<input type="text"/>
Nominal flow rate (ISO1217): Nemmvolumenstrom (ISO1217):	<input type="text"/> scfm
Working pressure PS min/max: Betriebsüberdruck PS min/max:	<input type="text"/> psig
Inlet temperature TS max: Eintrittstemperatur TS max:	<input type="text"/> °F
Ambient Temperature: Umgebungstemperatur:	<input type="text"/> °F
Refrigerant: Kältemittel:	<input type="text"/> type/oz
Refrig. Design Pres. HP/LP: Kältem. Auslegungsdruck HD/ND:	<input type="text"/> psig
Power supply: Elektrischer Anschluß:	<input type="text"/> V/ph/Hz
Electric Nominal Power: Elektrische Leistung:	<input type="text"/> W/A
Fuse protection max: Absicherung max:	<input type="text"/> A

TAD0011

 **BEKO TECHNOLOGIES GMBH**
Im Taubental 7, 41468 Neuss
Germany
<http://www.beko.de>



1.	Safety rules	4
1.1.	Definition of the Conventional Signs Used in This Manual.....	4
1.2.	Warnings	5
1.3.	Proper Use of the Dryer.....	5
1.4.	Instructions for the use of pressure equipment according to PED Directive 97/23/EC	6
2.	Installation	6
2.1.	Transport	6
2.2.	Storage	6
2.3.	Installation site	7
2.4.	Installation layout	7
2.5.	Correction factors	8
2.6.	Connection to the Compressed Air System	9
2.7.	Electrical connections.....	10
2.8.	Condensate Drain.....	10
3.	Start up	10
3.1.	Preliminary Operations	10
3.2.	First start-up	11
3.3.	Start-up and shut down	11
4.	Technical Specifications	12
4.1.	Technical Specifications DRYPOINT RA HT 20-150 P (115/1/60) NA	12
4.2.	Technical Specifications DRYPOINT RA HT 20-350 E (230/1/60) NA	13
5.	Technical description.....	14
5.1.	Control panel	14
5.2.	Operation.....	14
5.3.	Flow Diagram	15
5.4.	Refrigerating compressor	16
5.5.	Condenser	16
5.6.	Aftercooler	16
5.7.	Pre-Filter (1 micron)	16
5.8.	Capillary Tube.....	16
5.9.	Alu-Dry Module	16
5.10.	Hot Gas By-pass Valve	17
5.11.	Refrigerant Pressure Switches P_A - P_B - P_V	17
5.12.	Safety thermo-switch T_s	17
5.13.	DMC14 Electronic Instrument (Air Dryer Controller)	18
5.14.	Electronic level controlled condensate drain BEKOMAT.....	19
6.	Maintenance, troubleshooting, spares and dismantling	20
6.1.	Controls and Maintenance.....	20
6.2.	Troubleshooting.....	21
6.3.	Spare Parts.....	23
6.4.	Maintenance operation on the refrigerating circuit	25
6.5.	Dismantling of the Dryer	25
7.	List of attachments	26
7.1.	Dryers Dimensions	26
7.1.1.	Dryers Dimensions DRYPOINT RA HT 20-50 NA	26
7.1.2.	Dryers Dimensions DRYPOINT RA HT 75 NA.....	26
7.1.3.	Dryers Dimensions DRYPOINT RA HT 100-150 NA	27
7.1.4.	Dryers Dimensions DRYPOINT RA HT 200-250 NA	27
7.1.5.	Dryers Dimensions DRYPOINT RA HT 300-350 NA	27
7.2.	Exploded View.....	28
7.2.1.	Exploded view DRYPOINT RA HT 20-50 NA.....	29
7.2.2.	Exploded view DRYPOINT RA HT 75 NA	30
7.2.3.	Exploded view DRYPOINT RA HT 100 NA	31
7.2.4.	Exploded view DRYPOINT RA HT 150 NA	32
7.2.5.	Exploded view DRYPOINT RA HT 200-250 NA.....	33
7.2.6.	Exploded view DRYPOINT RA HT 300-350 NA.....	34
7.3.	Electrical Diagram	35
7.3.1.	Electrical Diagram DRYPOINT RA HT 20-50 P (115/1/60) NA.....	35
7.3.2.	Electrical Diagram DRYPOINT RA HT 20-50 E (230/1/60) NA.....	36
7.3.3.	Electrical Diagram DRYPOINT RA HT 75-100 P (115/1/60) NA.....	36
7.3.4.	Electrical Diagram DRYPOINT RA HT 75-100 E (230/1/60) NA.....	37
7.3.5.	Electrical Diagram DRYPOINT RA HT 150 P (115/1/60) NA	37
7.3.6.	Electrical Diagram DRYPOINT RA HT 150-250 E (230/1/60) NA.....	38
7.3.7.	Electrical Diagram DRYPOINT RA HT 300-350 E (230/1/60) NA.....	38

1. Safety rules

1.1. Definition of the Conventional Signs Used in This Manual



Carefully read instruction manual before attempting any service or maintenance procedures on the dryer.



Caution warning sign. Risk of danger or possibility of damage to equipment, if related text is not followed properly.



Electrical hazard. Warning message indicates practices or procedures that could result in personal injury or fatality if not followed correctly.



Danger hazard. Part or system under pressure.



Danger hazard. High temperature conditions exist during operation of system. Avoid contact until system or component has dissipated heat.



Danger hazard. Treated air is not suitable for breathing purposes; serious injury or fatality may result if precautions are not followed.



Danger hazard: In case of fire, use an approved fire extinguisher, water is not an acceptable means in cases of fire.



Danger hazard. Do not operate equipment with panels removed.



Maintenance or control operation to be performed by qualified personnel only¹.



Compressed air inlet connection point



Compressed air outlet connection point



Condensate drain connection point



Operations which can be performed by the operator of the machine, if qualified¹.

NOTE: Text that specifies items of note to be taken into account does not involve safety precautions.



In designing this unit a lot of care has been devoted to environmental protection:

- CFC free refrigerants
- CFC free insulation parts
- Energy saving design
- Limited acoustic emission
- Dryer and relevant packaging composed of recyclable materials

This symbol requests that the user heed environmental considerations and abide with suggestions annotated with this symbol.

¹ Experienced and trained personnel familiar with national and local codes, capable to perform the needed activities, identify and avoid possible dangerous situations while handling, installing, using and servicing the machine. Ensuring compliance to all statutory regulations.

1.2. Warnings



DANGER!
Compressed air!

Compressed air is a highly hazardous energy source.



Never work on the dryer with pressure in the system.

Never point the compressed air or the condensate drain outlet hoses towards anybody.

The user is responsible for the proper installation of the dryer. Failure to follow instructions given in the "Installation" chapter will void the warranty. Improper installation can create dangerous situations for personnel and/or damages to the machine could occur.



DANGER!
Supply voltage!

Only qualified personnel are authorized to service electrically powered devices. Before attempting maintenance, the following conditions must be satisfied:

- Ensure that main power is off, machine is locked out, tagged for service and power cannot be restored during service operations.
- Ensure that valves are shut and the air circuit is at atmospheric pressure. De-pressurize the dryer.



CAUTION!
Refrigerant!

These refrigerating air dryers contain R134a or R404A HFC type refrigerant fluid. Refer to the specific paragraph - maintenance operation on the refrigerating circuit.



WARNING!

Unauthorized interference!

Warranty does not apply to any unit damaged by accident, modification, misuse, negligence or misapplication. Unauthorized alterations will immediately void the warranty.



In case of fire, use an approved fire extinguisher, water is not an acceptable means in cases of electrical fire.

1.3. Proper Use of the Dryer

This dryer has been designed, manufactured and tested for the purpose of separating the humidity normally contained in compressed air. Any other use has to be considered improper.

The Manufacturer will not be responsible for any problem arising from improper use; the user will bear responsibility for any resulting damage.

Moreover, the correct use requires the adherence to the installation instructions, specifically:

- Voltage and frequency of the main power.
- Pressure, temperature and flow-rate of the inlet air.
- Ambient temperature.

This dryer is supplied tested and fully assembled. The only operation left to the user is the connection to the plant in compliance with the instructions given in the following chapters.



WARNING!
Improper use!

The purpose of the machine is the separation of water and eventual oil particles present in compressed air.

The dried air cannot be used for breathing purposes or for operations leading to direct contact with foodstuff.



This dryer is not suitable for the treatment of dirty air or of air containing solid particles.

Installation

1.4. Instructions for the use of pressure equipment according to PED Directive 97/23/EC

To ensure the safe operation of pressure equipments, the user must conform strictly to the above directive and the following:

1. The equipment must only be operated within the temperature and pressure limits stated on the manufacturer's data nameplate.
2. Welding on heat-exchanger is not recommended.
3. The equipment must not be stored in badly ventilated spaces, near a heat source or inflammable substances.
4. Vibration must be eliminated from the equipment to prevent fatigue failure.
5. Automatic condensate drains should be checked for operation every day to prevent a build up of condensate in the pressure equipment.
6. The maximum working pressure stated on the manufacturer's data nameplate must not be exceeded. Prior to use, the user must fit safety / pressure relief devices.
7. All documentation supplied with the equipment (manual, declaration of conformity etc.) must be kept for future reference.
8. Do not apply weights or external loads on the vessel or its connecting piping.



WARNING!

Unauthorized interference!

Users of the equipment must comply with all local and national pressure equipment legislation in the country of installation.

2. Installation

2.1. Transport

Check for visible loss or damage, if no visible damage is found place the unit near to the installation point and unpack the contents.

- Always keep the dryer in the upright vertical position. Damage to components could result if unit is laid on its side or if placed upside down.
- Store machine in a clean, dry environment, do not expose to severe weather environments.
- Handle with care. Heavy blows could cause irreparable damage.

2.2. Storage

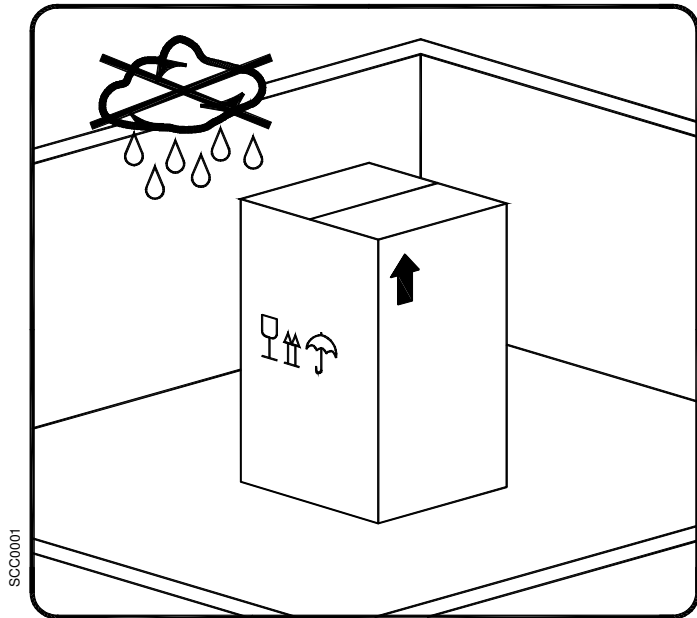

Even when packaged, keep the machine protected from severity of the weather.

Keep the dryer in vertical position, also when stored. Turning it upside down some parts could be irreparably damaged.

If not in use, the dryer can be stored in its packaging in a dust free and protected site at a maximum temperature of 120°F (50°C), and a specific humidity not exceeding 90%. Should the stocking time exceed 12 months, please contact the manufacturer.



The packaging materials are recyclable. Dispose of material in compliance with the rules and regulations in force in the destination country.

2.3. Installation site



CAUTION!
Ambient conditions!

Failure to install dryer in the proper ambient conditions will affect the dryer's ability to condense refrigerant gas. This can cause higher loads on the compressor, loss of dryer efficiency and performance, overheated condenser fan motors, electrical component failure and dryer failure due to the following: compressor loss, fan motor failure and electrical component failure. Failures of this type will affect warranty considerations. Do not install dryer in an environment of corrosive chemicals, explosive gasses, poisonous gasses; steam heat, areas of high ambient conditions or extreme dust and dirt.



In case of **fire**, use an approved fire extinguisher, **water** is not an acceptable means in cases of fire.

Minimum installation requirements:

- Select a clean dry area, free from dust, and protected from atmospheric disturbances.
- The supporting area must be smooth, horizontal and able to hold the weight of the dryer.
- Minimum ambient temperature +34 °F (+1 °C).
- Maximum ambient temperature +120°F (50°C).
- Allow at least a clearance of 40 in (1m) on each side of the dryer for proper ventilation and to facilitate eventual maintenance operations.

The dryer does not require attachment to the floor surface; however installations where the unit is suspended require an attachment to the hanging apparatus.

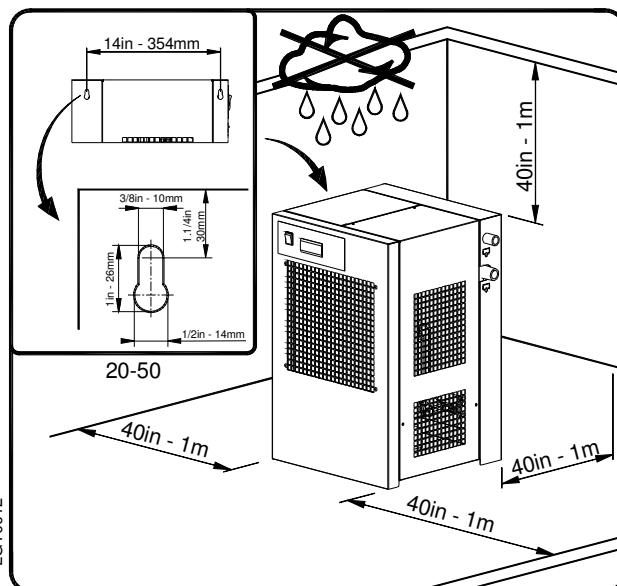

2.4. Installation layout

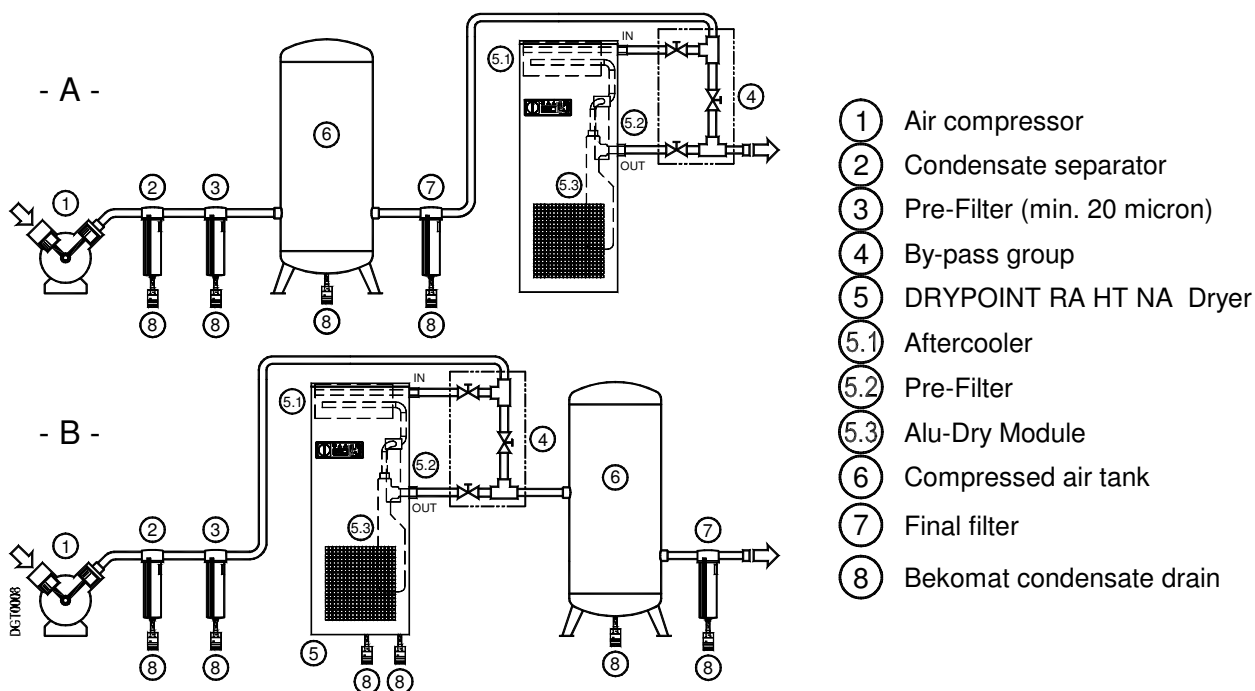

CAUTION!
Polluted inlet air!

In case of heavily polluted inlet air (ISO 8573.1 class 4.-.4 or worse quality), we recommend the additional installation of a pre-filter (f.e. CLEARPOINT W040) to prevent a clogging of the heat exchanger.

Type A installation is suggested when the compressor operates at reduced intermittence and the total consumption equals the compressor flow rate.

Type B installation is suggested when the air consumption can consistently change with peak values highly exceeding the flow rate of the compressor. The capacity of the tank must be sized in order to compensate eventual instantaneous demand conditions (peak air consumption).

Installation

2.5. Correction factors

Correction factor for operating pressure changes :

Inlet air pressure	60	80	100	120	140	160	180	200	220	230
	4	5.5	7	8	10	11	12.5	14	15	16
Factor (F1)	0.79	0.91	1.00	1.07	1.13	1.18	1.23	1.27	1.31	1.33

Correction factor for ambient temperature changes:

Ambient temperature	≤ 80	90	100	105	110	115	120
	≤ 27	32	38	40	43	46	50
Factor (F2)	1.22	1.11	1.00	0.94	0.89	0.83	0.78

Correction factor for inlet air temperature changes:

Air temperature	≤ 140	160	170	180	195	210
	≤ 60	70	76	82	90	100
Factor (F3)	1.26	1.13	1.07	1.00	0.90	0.81

Correction factor for DewPoint changes:

DewPoint	37	41	45	50
	3	5	7	10
Factor (F4)	0.78	0.90	1.00	1.12

How to find the air flow capacity:

Air flow capacity = Nominal duty x Factor (F1) x Factor (F2) x Factor (F3) x Factor (F4)

Example:

An **DRYPOINT RA HT 150 NA** has a nominal duty of **150 scfm (255 m³/h)**. What is the maximum allowable flow through the dryer under the following operating conditions:

- Inlet air pressure = 120 psig (8 barg) ⇒ Factor (F1) = 1.07
- Ambient temperature = 105°F (40°C) ⇒ Factor (F2) = 0.94
- Inlet air temperature = 195°F (90°C) ⇒ Factor (F3) = 0.90
- Pressure DewPoint = 45°F (7°C) ⇒ Factor (F4) = 1.00

Each item of data has a corresponding numerical factor which multiplied by the design air flow is as follows:

Air flow capacity = 150 x 1.07 x 0.94 x 0.90 x 1.00 = 137 scfm.

137 scfm This is the maximum flow rate that the dryer can accept under these operating conditions.

How to select a suitable dryer for a given duty:

Minimum std. air flow rate = $\frac{\text{Design air flow}}{\text{Factor (F1) x Factor (F2) x Factor (F3) x Factor (F4)}}$

Example:

With the following operating parameters:

- Design air flow = 95 scfm (161 m³/h)
- Inlet air pressure = 120 psig (8 barg) ⇒ Factor (F1) = 1.07
- Ambient temperature = 105°F (40°C) ⇒ Factor (F2) = 0.94
- Inlet air temperature = 195°F (90°C) ⇒ Factor (F3) = 0.90
- Pressure DewPoint = 45°F (7°C) ⇒ Factor (F4) = 1.00

In order to select the correct dryer model the required flow rate is to be divided by the correction factors relating to above mentioned parameters:

Minimum std. air flow rate = $\frac{95}{1.07 \times 0.94 \times 0.90 \times 1.00} = 104 \text{ scfm}$

Therefore the model suitable for the conditions above is **DRYPOINT RA HT 150 NA (150 scfm or 255 m³/h - nominal duty)**.

2.6. Connection to the Compressed Air System



DANGER!

Compressed air!

Operations to be performed by qualified personnel only.

Never work on compressed air system under pressure.



The user is responsible to ensure that the dryer will never be operated with pressure exceeding the maximum pressure rating on the unit data tag.

Over-pressurizing the dryer could be dangerous for both the operator and the unit.

The air temperature and the flow entering the dryer must comply within the limits stated on the data nameplate. The system connecting piping must be kept free from dust, rust, chips and other impurities, and must be consistent with the flow-rate of the dryer. In case of treatment of air at particularly high temperature, the installation of a final refrigerator could result necessary. In order to perform maintenance operations, it recommended that a dryer by-pass system be installed as shown in the following illustration.

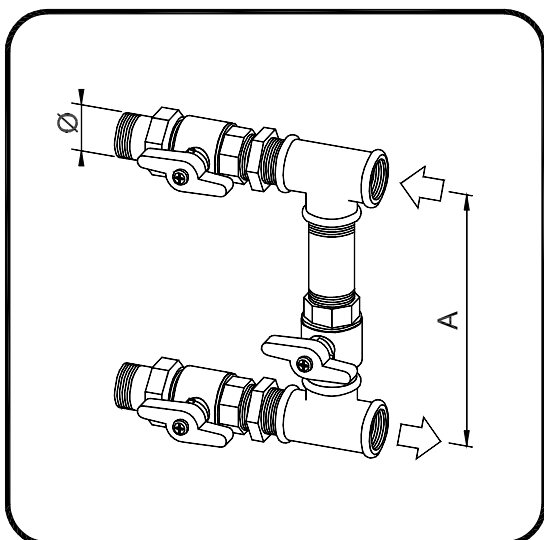

Dryer	Ø [BSP-F]	A [in - mm]
DRYPOINT RA HT 20-50 NA	1/2"	3 1/2" - 90
DRYPOINT RA HT 75 NA	1"	15 7/8" - 405
DRYPOINT RA HT 100-150 NA	1.1/4"	18 11/16" - 475
DRYPOINT RA HT 200-250 NA	1.1/2"	23 3/8" - 565
DRYPOINT RA HT 300-350 NA	2"	22 3/4" - 575

In realising the dryer, particular measures have been taken in order to limit the vibration which could occur during the operation. Therefore we recommend to use connecting pipes able to insulate the dryer from possible vibrations originating from the line (flexible hoses, vibration damping fittings, etc.).

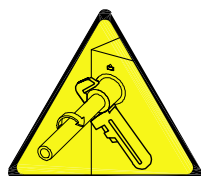

CAUTION:

Piping the dryer, inlet/outlet connections must be supported as show in the diagram. Failing will result in damage.

Start up

2.7. Electrical connections



DANGER!

Supply voltage!

Qualified personnel should carry out connecting unit to the main power.
Be sure to check the local codes in your area.

Before connecting the unit to the electrical supply, verify the identification plate for the proper electrical information. Voltage tolerance is +/- 5%.

Dryer supplied at 115/1/60 voltage comes with a mains connecting cable already installed and ending with a North-American standard plug 2 poles + ground. Dryer supplied at 230/1/60, voltages comes with a box for the connection to the mains.

Be sure to provide the proper fuses or breakers based on the data information located on the nameplate.

The mains socket must be provided with a mains magneto-thermal differential breaker ($\Delta n=0.03A$), adjusted on the basis of the consumption of the dryer (see the nominal values on the data plate of the dryer). The cross section of the power supply cables must comply with the consumption of the dryer, while keeping into account also the ambient temperature, the conditions of the mains installation, the length of the cables, and the requirements enforced by the local Power Provider.



DANGER!

Mains voltage and missing earthing!

Important: ensure that the plant is earthed.

Do not use any socket adapters at the mains plug.

If the mains plug needs to be replaced, this must only be done by a qualified electrician

2.8. Condensate Drain



DANGER!

Compressed air and pressurized condensate!

The condensate is discharge at the system pressure.

Drain line should be secured.



Never point the condensate drain line towards anybody.

The dryer comes already fitted with an electronically level controlled BEKOMAT condensate drain. Connect and properly fasten the condensate drain to a collecting plant or container.

The drain cannot be connected to pressurized systems.



Don't dispose the condensate in the environment.

The condensate collected in the dryer contains oil particles released in the air by the compressor.

Dispose the condensate in compliance with the local rules.

We suggest to install a water-oil separator where to convey all the condensate drain coming from compressors, dryers, tanks, filters, etc.

3. Start up

3.1. Preliminary Operations



CAUTION!

Exceeding of operating parameters!

Verify that the operating parameters match with the nominal values stated on the data nameplate of the dryer (voltage, frequency, air pressure, air temperature, ambient temperature, etc.).

This dryer has been thoroughly tested, packaged and inspected prior to shipment. Nevertheless, the unit could be damaged during transportation, check the integrity of the dryer during first start-up and monitor operation during the first hours of operation.



Qualified personnel must perform the first start-up.

When installing and operating this equipment, comply with all National Electrical Code and any applicable federal, state and local codes.



Who is operating the unit is responsible for the proper and safe operation of the dryer.

Never operate equipment with panels removed.

3.2. First start-up



This procedure should be followed on first start-up, after periods of extended shutdown or following maintenance procedures.

Qualified personnel must perform the start-up.

Sequence of operations (refer to paragraph 5.1 Control Panel).

- Ensure that all the steps of the “Installation” chapter have been observed.
- Ensure that the connection to the compressed air system is correct and that the piping is suitably fixed and supported.
- Ensure that the condensate drain pipe is properly fastened and connected to a collection system or container.
- Ensure that the by-pass system (if installed) is open and the dryer is isolated
- Ensure that the manual valve of the condensate drain circuit is open.
- Remove any packaging and other material which could obstruct the area around the dryer.
- Activate the mains switch.
- Turn on the main switch - pos. 1 on the control panel.
- Ensure that the electronic instrument DMC14 is ON.
- Ensure the consumption matches with the values of the data plate.
- **Ensure the fan work properly - wait for its first interventions (Air-Cooled).**
- Allow the dryer temperature to stabilise at the pre-set value.
- Slowly open the air inlet valve.
- Slowly open the air outlet valve.
- Slowly close the central by-pass valve of the system (if installed).
- Check the piping for air leakage.
- Ensure the drain is regularly cycling - wait for its first interventions.

3.3. Start-up and shut down



Start-up (refer to paragraph 5.1 Control Panel)

- Check the condenser for cleanliness.
- Verify that the system is powered.
- Activate the main switch - pos. 1 on the control panel.
- Ensure that electronic controller DMC14 is ON.
- Wait a few minutes; verify that the DewPoint temperature displayed on electronic instrument DMC14 is correct and that the condensate is regularly drained.
- Switch on the air compressor.



Shut down (refer to paragraph 5.1 Control Panel)

- Verify that the DewPoint temperature displayed on electronic controller DMC14 is correct.
- Switch OFF the air compressor.
- After a few minutes, switch off the main switch on the control panel of the dryer (pos. 1).

NOTE : A DewPoint within 32°F (0°C) and +60°F (15°C) displayed on DMC14 is correct according to the possible working conditions (flow-rate, temperature of the incoming air, ambient temperature, etc.).

During the operation, the refrigerating compressor will run continuously. The dryer must remain on during the full usage period of the compressed air, even if the air compressor works intermittently.



The **number of starts must be no more than 6 per hour**. The dryer must stop running for at least 5 minutes before being started up again.

The user is responsible for compliance with these rules. Frequent starts may cause irreparable damage.

4. Technical Specifications

4.1. Technical Specifications DRYPOINT RA HT 20-150 P (115/1/60) NA

DRYPOINT RA HT NA MODEL	P (115/1/60)						
	20	30	40	50	75	100	150
Air flow rate at nominal condition ¹	20	30	40	50	75	100	150
	[scfm]						
	20	30	40	50	75	100	150
	[m ³ /h]						
	34	51	68	85	127	170	255
	[l/min]						
	566	849	1132	1415	2123	2830	4245
Pressure DewPoint at nominal condition ¹	≤ 45 - ≤ 7						
	[°F - °C]						
Nominal (max.) ambient temperature	100 (120) - 38 (50)						
	[°F - °C]						
Min. ambient temperature	34 - 1						
	[°F - °C]						
Nominal (max.) inlet air temperature	180 (210) - 82 (100)						
	[°F - °C]						
Nominal inlet air pressure	100 - 7						
	[psig - barg]						
Max. inlet air pressure	230 - 16						
	[psig - barg]						
Air pressure drop - Δp	1.5 - 0.10	2.8 - 0.19	2.9 - 0.20	4.1 - 0.28	3.8 - 0.26	3.0 - 0.21	5.0 - 0.35
	[psi - bar]						
Inlet - Outlet connections	1/2"		1"		1.1/4"		
	[NPT-F]						
Refrigerant type	R134.a						
							R404A
Refrigerant quantity ²	7 - 0.20	8 - 0.22	10.1/4 - 0.29	14 - 0.40	16 - 0.45	20.1/2 - 0.58	
	[oz - kg]						
Cooling air flow	500 - 290						
	[cfm - m ³ /h]						
Pre-Filter (3 micron)	S040	S050	S075	M010	M015		
	[model]						
Nominal refrigerating compressor power	1/10	1/8	1/6	1/5+	1/3+	1/2	
	[Btu/h]						
Heat load	1680	2100	2500	3600	6200	8500	
	[PhV/Hz]						
Standard Power Supply ²	115/1/60						
Nominal electric absorption	210	280	310	460	770	880	1100
	[W]						
Max. electric absorption	2.3	2.5	3.1	4.7	8.3	8.7	10.1
	[A]						
Max. electric absorption	240	320	360	510	890	1020	1350
	[W]						
Max. level noise at 40 in (1m)	2.7	3.0	3.9	5.1	8.9	11.2	12.2
	[A]						
Max. level noise at 40 in (1m)	< 70						
	[dbA]						
Weight	66 - 30	68 - 31	71 - 32	73 - 33	110 - 50	134 - 61	146 - 66
	[lbs - kg]						

¹ The nominal condition refers to an ambient temperature of 100°F (38°C) with inlet air at 100psig (7barg) and 100°F (38°C).

² Check the data shown on the identification plate.

4.2. Technical Specifications DRYPOINT RA HT 20-350 E (230/1/60) NA

		E (230/1/60)										
DRYPOINT RA HT NA MODEL		20	30	40	50	75	100	150	200	250	300	350
Air flow rate at nominal condition ¹	[scfm]	20	30	40	50	75	100	150	200	250	300	350
	[m ³ /h]	34	51	68	85	127	170	255	340	425	509	594
	[l/min]	566	849	1132	1415	2123	2830	4245	5660	7075	8490	9905
Pressure DewPoint at nominal condition ¹	[°F - °C]	≤ 45 - ≤ 7										
Nominal (max.) ambient temperature	[°F - °C]	100 (120) - 38 (50)										
Min. ambient temperature	[°F - °C]	34 - 1										
Nominal (max.) inlet air temperature	[°F - °C]	180 (210) - 82 (100)										
Nominal inlet air pressure	[psig - barg]	100 - 7										
Max. inlet air pressure	[psig - barg]	230 - 16										
Air pressure drop - Δp	[psi - bar]	1.5 - 0.10	2.8 - 0.19	2.9 - 0.20	4.1 - 0.28	3.8 - 0.26	3.0 - 0.21	5.0 - 0.35	3.3 - 0.23	5.1 - 0.35	4.1 - 0.28	4.5 - 0.31
Inlet - Outlet connections	[NPT-F]	1/2"		1/4		1"		1.1/4"		1.1/2"		2"
Refrigerant type		R134.a					R404A					
Refrigerant quantity ²	[oz - kg]	7-0.20	8-0.22	10.1/4 - 0.29		14-0.40	16-0.45	20.1/2-0.58	30.1/2-0.87	33.1/2-0.95	44-1.25	50-1.40
Cooling air flow	[cfm - m ³ /h]	500 - 290		900 - 530		1000 - 590		1500 - 880		3500 - 2060		6150 - 3700
Nominal refrigerating compressor power		1/10	1/6	1/4		1/3+		1/2		5/8		1.1/8
Pre-Filter (3 micron)	[model]	S040	S050	S075		M010		M015		M020		
Heat load	[Btu/h]	1680		2500		4000		6200		8500		11900
Standard Power Supply ²	[PhV/Hz]	230/1/60										
Nominal electric absorption	[W]	210	280	310	460	770	880	1100	1550	1820	2600	2700
	[A]	1.1	1.3	1.6	2.3	4.2	4.3	5.1	7.0	8.1	12.1	12.8
Max. electric absorption	[W]	240	320	360	510	890	1020	1350	1650	2280	3300	3420
	[A]	1.4	1.5	1.9	2.5	4.5	5.6	6.1	7.3	10.4	15.0	15.6
Max. level noise at 40 in (1m)	[dba]	< 70										
Weight	[lbs - kg]	66 - 30	68 - 31	71 - 32	73 - 33	110 - 50	134 - 61	146 - 66	165 - 75	185 - 84	291 - 132	304 - 138

¹ The nominal condition refers to an ambient temperature of 100°F (38°C) with inlet air at 100psig (7barg) and 100°F (38°C).

² Check the data shown on the identification plate.

5. Technical description

5.1. Control panel

The control panel illustrated below is the only dryer-operator interface.

DRYPOINT RA HT 20 – 100 NA

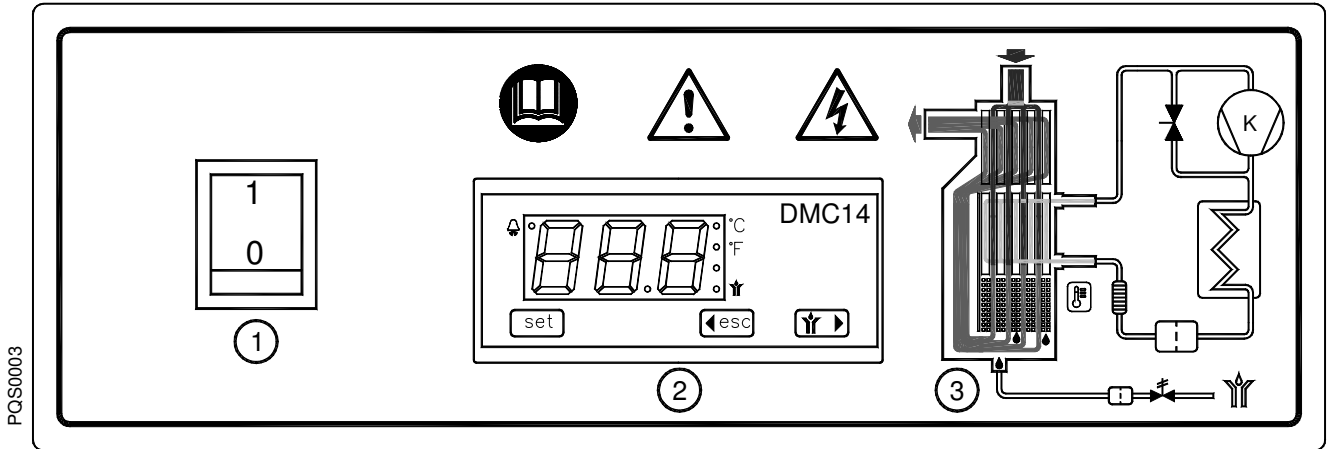

DRYPOINT RA HT 150 – 350 NA

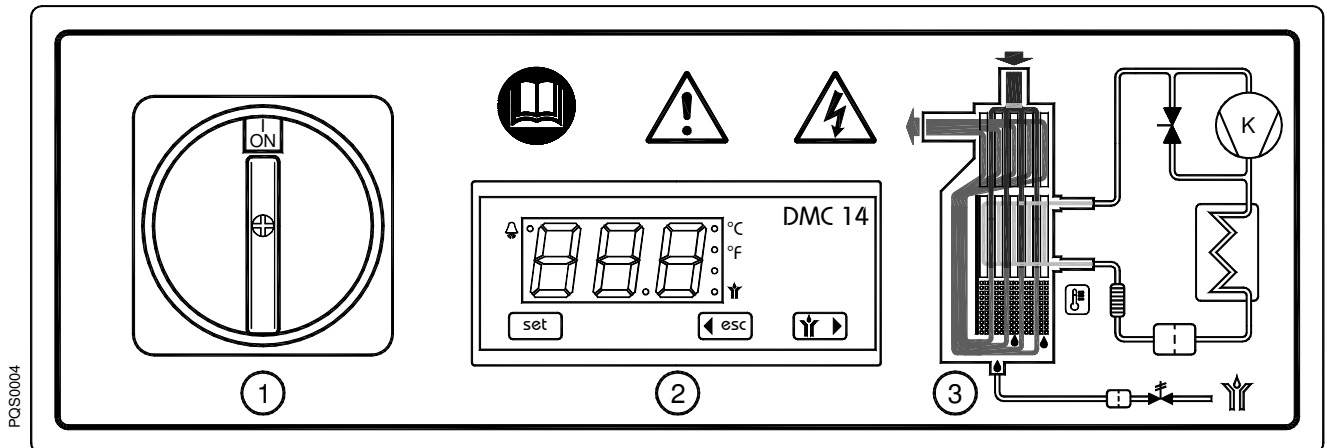

- ① Main switch
- ② Electronic control instrument DMC14
- ③ Air and refrigerating gas flow diagram

5.2. Operation

Operating principal – The dryer models described in this manual all operate on the same principal. First the very hot moisture laden air directly from the compressor enters the aftercooler (copper tube / aluminum fin cooling surface) where it is cooled to within 18-20°F (10-12°C) of the ambient air temperature. It leaves the aftercooler with entrained condensed water droplets which are separated by the 1 micron bulk liquid filter separator element and drained away by the first drain system. The partially cooled moisture laden air next enters an air to air heat exchanger to pre-cool it. The compressed air next goes through the evaporator, also known as the air to refrigerant heat exchanger. The compressed air temperature is reduced to approximately 41°F (5°C), causing additional water vapor to condense to liquid. The liquid is continuously coalesced and collected in the dryer separator for automatic removal by the second condensate drain. The cool moisture free compressed air then passes back through the air to air heat exchanger to be reheated to within the ambient temperature as it exits the dryer.

Refrigerant circuit - Refrigerant gas is cycled through the compressor and exits at high pressure to a condenser where heat is removed causing the refrigerant to condense to a high-pressure liquid state. The liquid is forced through a capillary tube where the resulting pressure drop allows the refrigerant to boil off at a predetermined temperature. Low-pressure liquid refrigerant enters the heat exchanger where heat from the incoming air is transferred causing the refrigerant to boil; the resulting phase change produces a low pressure, low temperature gas. The low-pressure gas is returned to the compressor, where it is re-compressed and begins the cycle again. During those periods when the compressed air load is reduced the excess refrigerant is by-passed automatically back to the compressor via the Hot Gas By-pass Valve circuit.

5.3. Flow Diagram

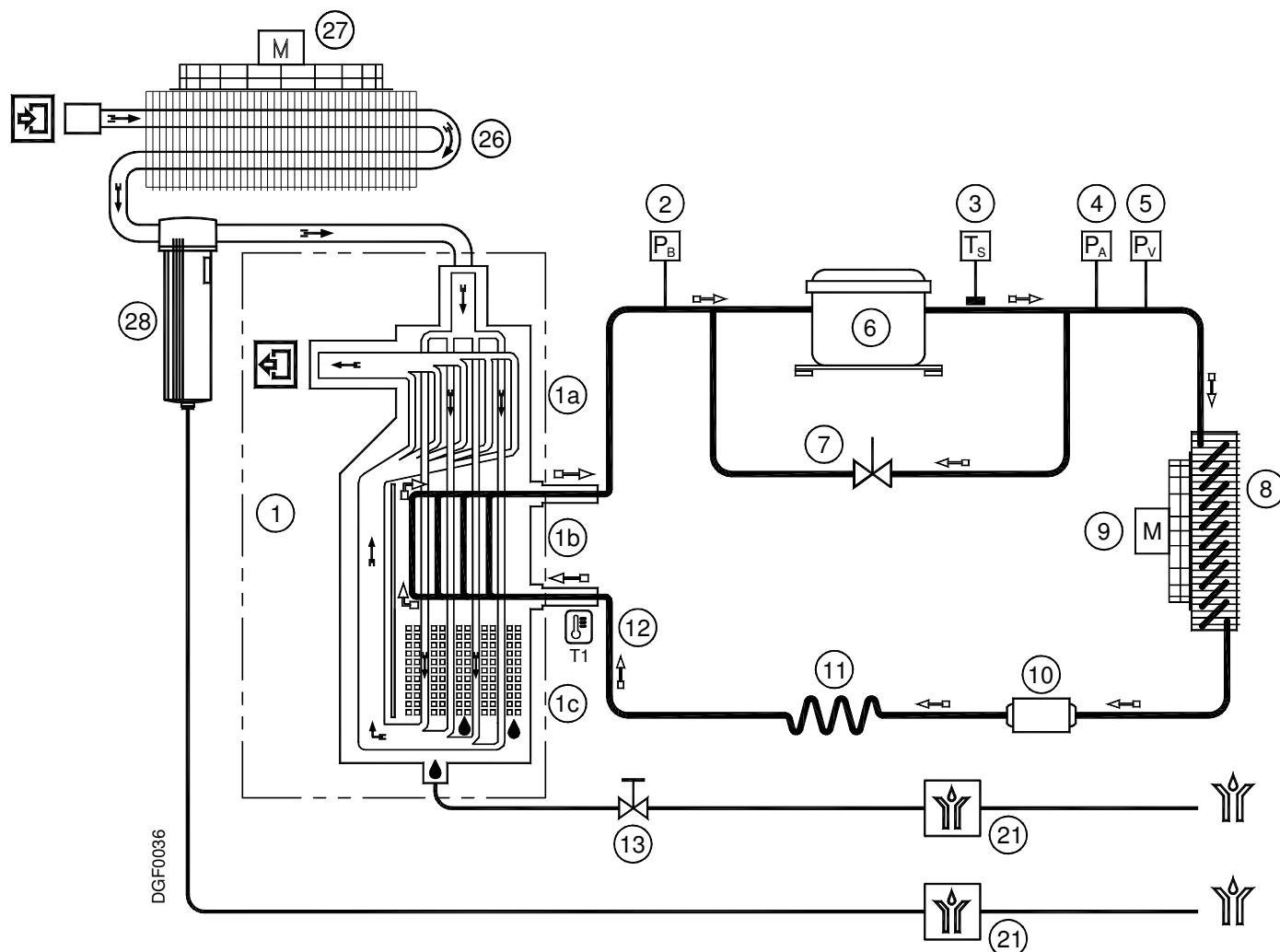

- | | |
|-----------------------------------------------------------------|----------------------------------------------|
| ① Alu-Dry Module | ⑨ Condenser fan |
| a - Air-to-air heat exchanger | ⑩ Filter drier |
| b - Air-to-refrigerant exchanger | ⑪ Capillary tube |
| c - Condensate separator | ⑫ T1 Temperature probe (DewPoint) |
| ② Refrigerant pressure-switch P_B (DRYPOINT RA HT 300-350 NA) | ⑬ Condensate drain isolation valve |
| ③ Safety thermo-switch T_S (DRYPOINT RA HT 150-350 NA) | ... |
| ④ Refrigerant pressure-switch P_A (DRYPOINT RA HT 300-350 NA) | ⑳ Bekomat drainer |
| ⑤ Refrigerant Fan pressure-switch P_V | ... |
| ⑥ Refrigeration compressor | ㉑ Aftercooler |
| ⑦ Hot gas by-pass valve | ㉒ Aftercooler fan (DRYPOINT RA HT 75-350 NA) |
| ⑧ Condenser | ㉓ Pre-Filter (1 micron) |

➡ Compressed air flow direction

➡ Refrigerating gas flow direction

Technical description

5.4. Refrigerating compressor

The refrigerating compressor is the pump in the system, gas coming from the evaporator (low pressure side) is compressed up to the condensation pressure (high pressure side). The compressors utilized are manufactured by leading manufacturers and are designed for applications where high compression ratios and wide temperature changes are present.

The hermetically sealed construction is perfectly gas tight, ensuring high-energy efficiency and long, useful life. Dumping springs support the pumping unit in order to reduce the acoustic emission and the vibration diffusion. The aspirated refrigerating gas, flowing through the coils before reaching the compression cylinders cools the electric motor. The thermal protection protects the compressor from over heating and over currents. The protection is automatically restored as soon as the nominal temperature conditions are reached.

5.5. Condenser

The condenser is the component in which the gas coming from the compressor is cooled down and condensed becoming a liquid. Mechanically, a serpentine copper tubing circuit (with the gas flowing inside) is encapsulated in an aluminum fin package.

The cooling operation occurs via a high efficiency fan, creating airflow within the dryer, moving air through the fin package. It's mandatory that the ambient air temperature does not exceed the nominal values. It is also important **to keep the condenser unit free from dust and other impurities.**

5.6. Aftercooler

The aftercooler is the element where the incoming hot air undergoes the cooling stage. Mechanically, it is formed by a copper tubing circuit (with the compressed air flowing inside) immersed in an aluminium blades package. The cooling operation occurs via a high efficiency axial ventilator which, in applying pressure on the air contained within the dryer, forces it into the blades package. In models **DRYPOINT RA HT 20-50 NA** the aftercooler is combined with the dryer's condenser, thus forming just one heat exchanger battery, cooled by just one high efficiency axial fan.

It is mandatory that the temperature of the ambient air will not exceed the nominal values of the dryer. It is important **TO KEEP THE UNIT FREE FROM DUST AND OTHER IMPURITIES** taken in by the fan.

5.7. Pre-Filter (1 micron)

Positioned at the outlet of the aftercooler, it assures a good air cleanliness level, in addition to the complete removal of the water condensed in the aftercooler. **REPLACE THE FILTERING ELEMENT (CARTRIDGE) AT LEAST EVERY 12 MONTHS.**

5.8. Capillary Tube

It consists of a piece of reduced cross section copper tubing located between the condenser and the evaporator, acting as a metering device to reduce the pressure of the refrigerant. Reduction of pressure is a design function to achieve optimum temperature reached within the evaporator: the smaller the capillary tube outlet pressure, the lower the evaporation temperature.

The length and interior diameter of the capillary tubing is accurately sized to establish the performance of the dryer; no maintenance or adjustment is necessary.

5.9. Alu-Dry Module

The air-to-air and the air-to-refrigerant heat exchangers plus the demister type condensate separator are housed in a unique module.

The counter-flows of compressed air in the air-to-air heat exchanger ensure maximum heat transfer. The large cross section of flow channels within the heat exchanger module leads to low velocities and reduced power requirements. The air-to-refrigerant exchanger, with counter-current flows, assure excellent performances. The generous dimensions of the exchange surface determines the correct and complete evaporation of the refrigerant (preventing liquid returning to the compressor). The high efficiency condensate separator is located within the drying module. No maintenance is required and it offers the additional advantage of creating a cold coalescing effect for excellent air drying results. The generous collection volume assures the correct operation of the dryer even with extremely damp inlet air.

5.10. Hot Gas By-pass Valve

This valve injects part of the hot gas (taken from the discharge side of the compressor) in the pipe between the evaporator and the suction side of the compressor, keeping the evaporation temperature/pressure constant at approx. 36°F (+2 °C). This injection prevents the formation of ice inside the dryer evaporator at every load condition.



ADJUSTMENT

The Hot Gas By-pass Valve is adjusted during the manufacturing testing phase. As a rule no adjustment is required; anyway if it is necessary the operation must be carried out by an experienced refrigerating engineer.

WARNING!

the use of 1/4" Schrader service valves must be justified by a real malfunction of the refrigerating system. Each time a pressure gauge is connected, a part of refrigerant is exhausted.

Without compressed air flow through the dryer, rotate the adjusting screw (position A on the drawing) until the following value is reached:

- | | |
|----------------------------|------------------------------------|
| Hot gas setting (R134.a) : | temperature 33°F (+1 / -0 °F) |
| | pressure 29 psig (+1.5 / -0 psi) |
| | temperature 0.5°C (+0.5 / -0 °K) |
| | pressure 2.0 barg (+0.1 / -0 bar) |
| Hot gas setting (R404A) : | temperature 33°F (+1 / -0 °F) |
| | pressure 75.4 psig (+1.5 / -0 psi) |
| | temperature 0.5 °C (+0.5 / -0 °K) |
| | pressure 5.2 barg (+0.1 / -0 bar) |

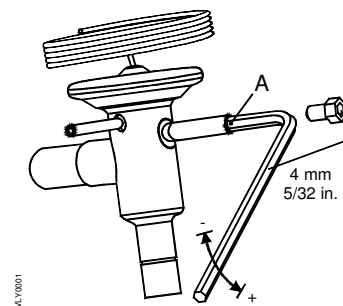

5.11. Refrigerant Pressure Switches P_A-P_B-P_V

As operation safety and protection of the dryer a series of pressure switches are installed in the gas circuit.

PB : Low-pressure controller device on the pushing side (carter) of the compressor, is enabled only if the pressure drops below the pre-set value. The values are automatically reset when the nominal conditions are restored.

- | | | |
|-----------------------|---------|------------------------------------|
| Calibrated pressure : | R 404 A | Stop 14.5 psig - Restart 72.5 psig |
| | R 404 A | Stop 1.0 barg - Restart 5.0 barg |

PA : This high-pressure controller device, located on the pushing side on the compressor, is activated when the pressure exceeds the pre-set value. It features a manual-resetting button mounted on the controller itself.

- | | | |
|-----------------------|---------|------------------------------|
| Calibrated pressure : | R 404 A | Stop 464 psig - Manual reset |
| | R 404 A | Stop 32 barg - Manual reset |

PV : Fan control pressure switch is placed at the discharge side of refrigeration compressor. It keeps the condensation temperature/pressure constant within preset limits (Air-Cooled).

- | | | |
|-----------------------|---------|--------------------------------------------------------------------|
| Calibrated pressure : | R 134.a | Start 160 psig (117°F) - Stop 116 psig (97°F) - Tolerance ± 15 psi |
| | R 134.a | Start 11 barg (47°C) - Stop 8 barg (36°C) - Tolerance ± 1 bar |
| | R 404 A | Start 290 psig (113°F) - Stop 232 psig (97°F) - Tolerance ± 15 psi |
| | R 404 A | Start 20 barg (45°C) - Stop 16 barg (36°C) - Tolerance ± 1 bar |

5.12. Safety thermo-switch T_s

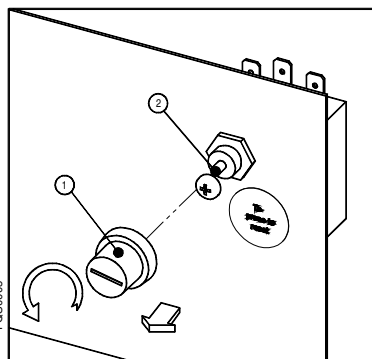

To protect the operating safety and the integrity of the dryer, a thermo-switch (T_s) is installed on the refrigerant gas circuit. The thermo-switch sensor, in case of unusual discharge temperatures, stops the refrigerating compressor before it is permanently damaged.

Manually reset the thermo-switch only after the nominal operating conditions have been restored. Unscrew the relative cap (see pos.1 in the figure) and press the reset button (see pos.2 in the figure).

- | | |
|--------------|---------------------------------|
| TS setting : | temperature 212 °F (+4 / -4 °F) |
| | temperature 100 °C (+2 / -2 °K) |

Technical description

5.13. DMC14 Electronic Instrument (Air Dryer Controller)

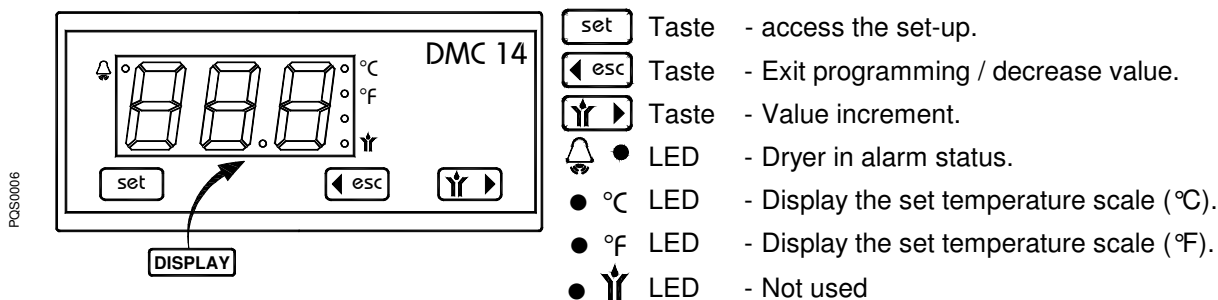

Through the digital thermometer with an alphanumeric display, the DMC14 controller shows the DewPoint detected by the probe in the evaporator.

The LED shows any alarm condition, it can happen when :

- pressure DewPoint is too high;
- pressure DewPoint is too low;
- the probe is faulty.

If the probe is faulty, the instrument also shows "PF" message (Probe Failure), and alarm activation is immediate. In case of "DewPoint too low" condition (ASL parameter, that is fix and equal to 28.5°F or -2°C), the alarm signal is delayed of a fix time (AdL parameter) equal to 30 sec, while for "DewPoint too high" condition the value (ASH parameter) is set by the user and the signal is activated with AdH delay time, that can be also set up by the operator (the instrument is already adjusted during final test of the dryer, please see following values). When DewPoint returns into operating temperature (set range), the alarm condition is deactivated.

DMC14 allows also remote annunciation of the alarm condition of the dryer; this through a volt free contact on terminals 8 & 9 - please also see electric drawings into the attachments (max 250V 1A, min 5VDC 10mA)

- with dryer off or in alarm conditions contact is open
- with dryer on and correct operating DewPoint, contact is closed.

OPERATION - After dryer starting, the electronic controller displays current operating DewPoint : it shows the measured temperature in Celsius degrees (• °C) with a 0.5°C resolution, or in Fahrenheit degrees (• °F) with a 1°F resolution.

SET-UP (PROGRAMMING)

To access the set-up, keep pressed simultaneously both and button for at least 5 seconds. In this way **programming operation will be activated** and the controller display shows the first parameter that can be set (Ton).

After that, by pressing button the display shows the value set for that parameter. If the value is correct press button to confirm it and to give access on following parameters. To change the value of selected parameter, must be used and button, respectively to decrease or increase the value. All parameters that can be modified are indicated in following table :

Display	Description	Value range	Set value	Equal to
Ton	Not used	01 ... 20	02	2 sec
ToF	Not used	01 ... 20	01	1 min
ASH	Alarm threshold for a high DewPoint .	0.0 ... 68.0	60	60°F
AdH	ASH alarm time before signal	00 ... 20	20	20 min
SCL	Temperature scale	°C ... °F	°F	°Fahrenheit
Fixed parameters :	ASL (low DewPoint alarm) = -2°C or 28.5°F	AdL (signal delay) = 30 sec		

It is possible to exit from set-up condition in any moment, by pressing simultaneously both and button. If any operations are not made during 30 seconds, the controller exits automatically from programming operation.

5.14. Electronic level controlled condensate drain BEKOMAT

The electronic level controlled drain BEKOMAT has a special condensate management that makes sure that condensate is drained safely without any unnecessary air-loss. This drain consists of a condensate accumulator where a capacitive sensor continuously checking liquid level is placed: as soon as the accumulator is filled, the sensor passes a signal to the electronic control and a diaphragm solenoid valve will open to discharge the condensate. Right in time the discharge line will be closed again without wasting compressed air.

ATTENTION!

These BEKOMAT condensate drains have been specially designed for the use in a refrigerant dryer **DRYPOINT RA HT NA**. Any Installation in other compressed air treatment units or the exchange against a different drain brand may lead to malfunction. Do not exceed the max. operating pressure (see type plate)!

Make sure when the dryer starts the upstream valve is open.

NOTE:

For detailed information on drainer functions, troubleshooting, service and replacement parts, please refer to the BEKOMAT drainer manual.

6. Maintenance, troubleshooting, spares and dismantling

6.1. Controls and Maintenance



DANGER!

Compressed air, mains voltage, unqualified personnel!

Only qualified personnel should perform troubleshooting and or maintenance operations. Prior to performing any maintenance or service, be sure that:

- no part of the machine is powered and that it cannot be connected to the mains supply.
- no part of the machine is under pressure and that it cannot be connected to the compressed air system.
- Maintenance personnel have read and understand the safety and operation instructions in this manual.



Before attempting any maintenance operation on the dryer, shut it down and wait at least 30 minutes.

DANGER!

Hot surfaces!



Some components can reach high temperature during operation. Avoid contact until system or component has dissipated heat.



DAILY:

Verify that the DewPoint displayed on the electronic instrument is correct.
Check the proper operation of the condensate drain systems.
Verify the condenser for cleanliness.

EVERY 200 HOURS OR MONTHLY



MAX 2 bars / 30 Psig

With an air jet (max. 2 bar / 30 psig) blowing from inside towards outside clean the condenser; repeat this operation blowing in the opposite way; be careful not to damage the aluminum fins of the cooling package.

- At the end, check the operation of the machine.



EVERY 1000 HOURS OR YEARLY

- Verify for tightness all the screws of the electric system and that all the “Faston” type connections are in their proper position, inspect unit for broken, cracked or bare wires.
- Inspect refrigerating circuit for signs of oil and refrigerant leakage.
- Measure and record amperage. Verify that readings are within acceptable parameters as listed in specification table.
- Inspect condensate drain flexible hoses, and replace if necessary.
- Replace the filter element (cartridge) of the Pre-Filter (1 micron). Refer to the instructions in the user’s and maintenance manual of the filter for this operation.
- At the end, check the operation of the machine.

6.2. Troubleshooting



Only qualified personnel should perform troubleshooting and or maintenance operations. Prior to performing any maintenance or service, be sure that:

- no part of the machine is powered and that it cannot be connected to the mains supply.
- no part of the machine is under pressure and that it cannot be connected to the compressed air system.
- Maintenance personnel have read and understand the safety and operation instructions in this manual.







Before attempting any maintenance operation on the dryer, shut it down and wait at least 30 minutes. Some components can reach high temperature during operation. Avoid contact until system or component has dissipated heat



SYMPTOM	POSSIBLE CAUSE - SUGGESTED ACTION
◆ The dryer doesn't start.	⇒ Verify that the system is powered. ⇒ Verify the electric wiring.
◆ The compressor doesn't work.	⇒ Activation of the compressor internal thermal protection - wait for 30 minutes, then retry. ⇒ Verify the electric wiring. ⇒ Where installed - Replace the internal thermal protection and/or the start-up relay and/or the start-up capacitor and/or the working capacitor. ⇒ Where installed - The pressure switch PA has been activated - see specific point. ⇒ Where installed - The pressure switch PB has been activated - see specific point. ⇒ Where installed - The safety thermo-switch TS has been activated - see specific point. ⇒ If the compressor still doesn't work, replace it.
◆ The fan of the condenser doesn't work.	⇒ Verify the electric wiring. ⇒ PV pressure switch is faulty - replace it. ⇒ There is a leak in the refrigerating fluid circuit - contact a refrigeration engineer. ⇒ If the fan still doesn't work, replace it.
◆ DRYPOINT RA HT 75-350 NA - The Aftercooler fan doesn't work.	⇒ Verify the electric wiring. ⇒ If the fan still doesn't work, replace it.
◆ DewPoint too high.	⇒ The dryer doesn't start - see specific point. ⇒ The T1 DewPoint probe doesn't correctly detect the temperature - ensure the sensor is pushed into the bottom of copper tube immersion well. ⇒ The refrigerating compressor doesn't work - see specific point. ⇒ The ambient temperature is too high or the room aeration is insufficient - provide proper ventilation. ⇒ The inlet air is too hot - restore the nominal conditions. ⇒ The inlet air pressure is too low - restore the nominal conditions. ⇒ The inlet air flow rate is higher than the rate of the dryer - reduce the flow rate - restore the normal conditions. ⇒ The condenser is dirty - clean it. ⇒ The aftercooler is dirty - clean it. ⇒ The condenser fan doesn't work - see specific point. ⇒ The aftercooler fan doesn't work - see specific point. ⇒ The dryer doesn't drain the condensate - see specific point. ⇒ The hot gas by-pass valve is out of setting - contact a refrigeration engineer to restore the nominal setting. ⇒ There is a leak in the refrigerating fluid circuit - contact a refrigeration engineer.

Maintenance, troubleshooting, spares and dismantling

- | | |
|-------------------------------------------------------------------------------------------------------------------------------------------------------------------------------|-----------------------------------------------------------------------------------------------------------------------------------------------------------------------------------------------------------------------------------------------------------------------------------------------------------------------------------------------------------------------------------------------------------------------------------------------------------------------------------------------------------------------------------------------------------------------------------------------------------------------------------------------------------------------------------------------|
| ◆ DewPoint too low. | ⇒ The fan is always ON - PV pressure switch is faulty - replace it.
⇒ The Hot Gas By-pass Valve is out of setting - contact a refrigeration engineer to restore the nominal setting.
⇒ Ambient temperature is too low - restore de nominal condition. |
| ◆ Excessive pressure drop within the dryer. | ⇒ The Pre-Filter (1 micron) is clogged - replace the filter element (cartridge) - Refer to the instructions in the user's and maintenance manual of the filter.
⇒ The dryer doesn't drain the condensate - see specific point.
⇒ The DewPoint is too low - the condensate is frost and blocks the air - see specific point.
⇒ Check for throttling the flexible connection hoses. |
| ◆ The dryer doesn't drain the condensate. | ⇒ The condensate drain service valve is closed - open it.
⇒ Verify the electric wiring.
⇒ The DewPoint is too low - the condensate is frozen - see specific point.
⇒ Bekomat drainer is not operating correctly (see BEKOMAT MANUAL) |
| ◆ The dryer continuously drains condensate. | ⇒ Bekomat drainer is dirty (see BEKOMAT MANUAL) |
| ◆ Water within the line. | ⇒ The dryer doesn't start - see specific point.
⇒ Where installed - Untreated air flows through the by-pass unit - close the by-pass.
⇒ The dryer doesn't drain the condensate - see specific point.
⇒ DewPoint too high - see specific point. |
| ◆ Where installed - The PA high-pressure switch has been activated. | ⇒ Check which of the following has caused the activation :
1. The ambient temperature is too high or the room aeration is insufficient - provide proper ventilation.
2. The condenser is dirty - clean it.
3. The condenser fan doesn't work - see specific point.
⇒ Reset the pressure-switch pressing the button on the controller itself - verify the dryer for correct operation.
⇒ The PA pressure switch is faulty - contact a refrigeration engineer to replace it. |
| ◆ Where installed - The PB low-pressure switch has been activated. | ⇒ There is a leak in the refrigerating fluid circuit - contact a refrigeration engineer.
⇒ The pressure switch restores automatically when normal conditions are restored - check the proper operation of the dryer. |
| ◆ Where installed - The TS safety thermo-switch has been activated. | ⇒ Check which of the following has caused the activation :
1. Excessive thermal load – restore the standard operating conditions.
2. The inlet air is too hot - restore the nominal conditions.
3. The ambient temperature is too high or the room aeration is insufficient - provide proper ventilation.
4. The condenser unit is dirty - clean it.
5. The fan doesn't work - see specific point.
6. There is a leak in the refrigerating fluid circuit - contact a refrigeration engineer.
⇒ Reset the thermo-switch by pressing the button on the thermo-switch itself – verify the correct operation of the dryer.
⇒ The TS thermo-switch is faulty - replace it. |
| ◆ DMC14 - The LED  of the instrument is on or flashes to indicate alarm situations. | ⇒ The LED  flashes because the DewPoint is too high – see specific point.
⇒ The LED  flashes because the DewPoint is too low - see specific point.
⇒ The LED  flashes because the probe is faulty or interrupted, the instrument displays the message "PF" (Probe Failure) – replace the probe. |
-

6.4. Maintenance operation on the refrigerating circuit



CAUTION! Refrigerant!

Maintenance and service on refrigerating systems must be carried out only by certified refrigerating engineers only, according to local rules.

All the refrigerant of the system must be recovered for its recycling, reclamation or destruction.

Do not dispose the refrigerant fluid in the environment.

This dryer comes ready to operate and filled with R134a or R404A type refrigerant fluid.



In case of refrigerant leak contact a certified refrigerating engineers. Room is to be aired before any intervention.

If is required to re-fill the refrigerating circuit, contact a certified refrigerating engineers.

Refer to the dryer nameplate for refrigerant type and quantity.

Characteristics of refrigerants used:

Refrigerant	Chemical formula	TLV	GWP
R134a - HFC	CH ₂ FCF ₃	1000 ppm	1300
R404A - HFC	CH ₂ FCF ₃ /C ₂ HF ₅ /C ₂ H ₃ F ₃	1000 ppm	3784

6.5. Dismantling of the Dryer

If the dryer is to be dismantled, it has to be split into homogeneous groups of materials.



Part	Material
Refrigerant fluid	R404A, R134a, Oil
Canopy and Supports	Carbon steel, Epoxy paint
Refrigerating compressor	Steel, Copper, Aluminium, Oil
Alu-Dry Module	Aluminium
Condenser Unit	Aluminium, Copper, Carbon steel
Pipe	Copper
Fan	Aluminium, Copper, Steel
Valve	Brass, Steel
Electronic Level Drain	PVC, Aluminium, Steel
Insulation Material	Synthetic gum without CFC, Polystyrene, Polyurethane
Electric cable	Copper, PVC
Electric Parts	PVC, Copper, Brass



We recommend to comply with the safety rules in force for the disposal of each type of material.

The chilling fluid contains droplets of lubrication oil released by the refrigerating compressor.

Do not dispose this fluid in the environment. It has to be discharged from the dryer with a suitable device and then delivered to a collection centre where it will be processed to make it reusable.

List of attachments

7. List of attachments

7.1. Dryers Dimensions

7.1.1. Dryers Dimensions DRYPOINT RA HT 20-50 NA

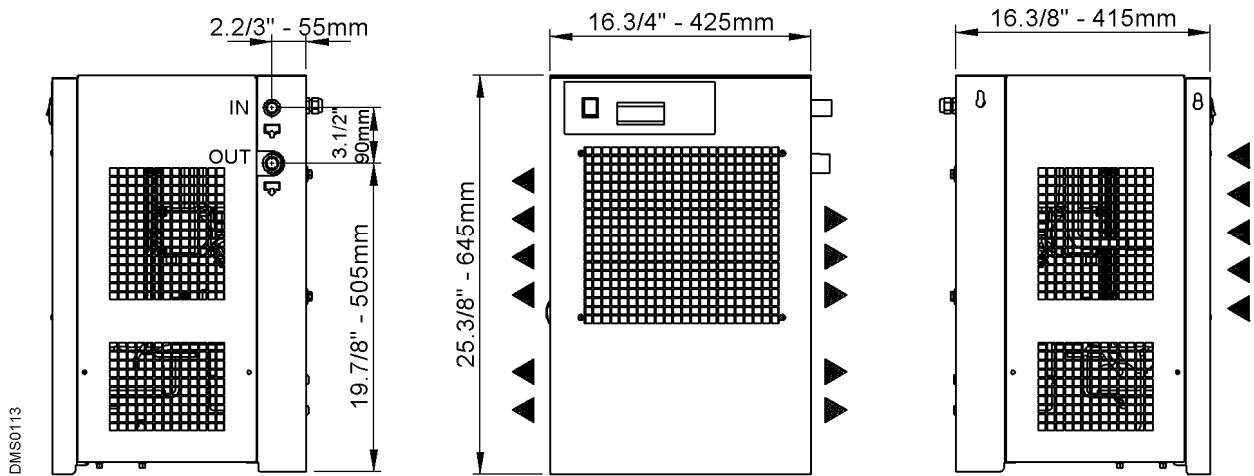

7.1.2. Dryers Dimensions DRYPOINT RA HT 75 NA

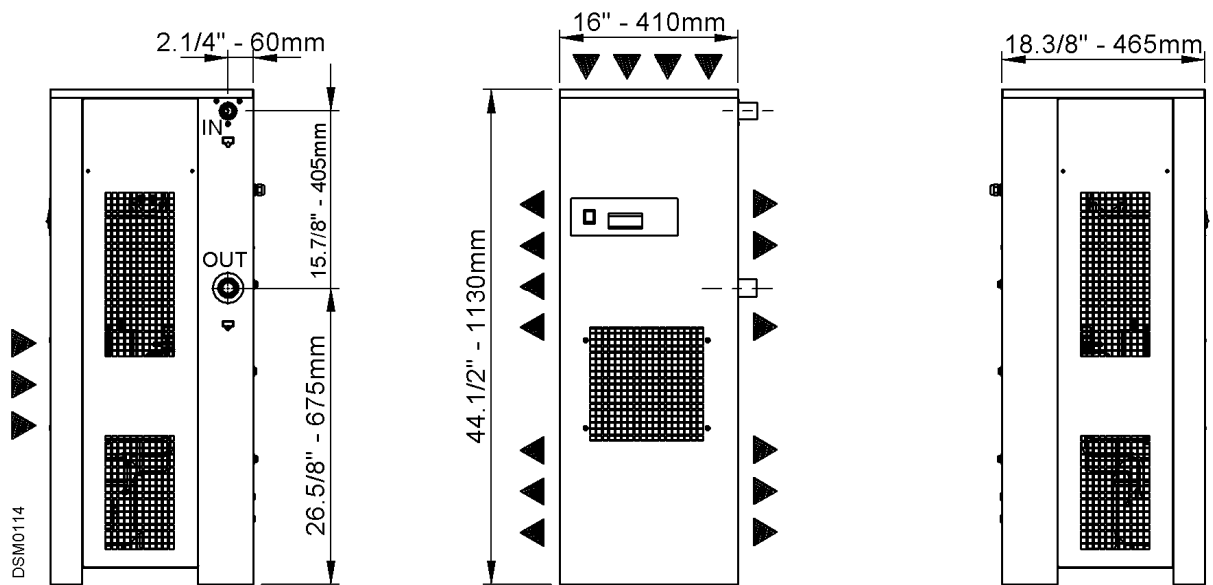

7.1.3. Dryers Dimensions DRYPOINT RA HT 100-150 NA

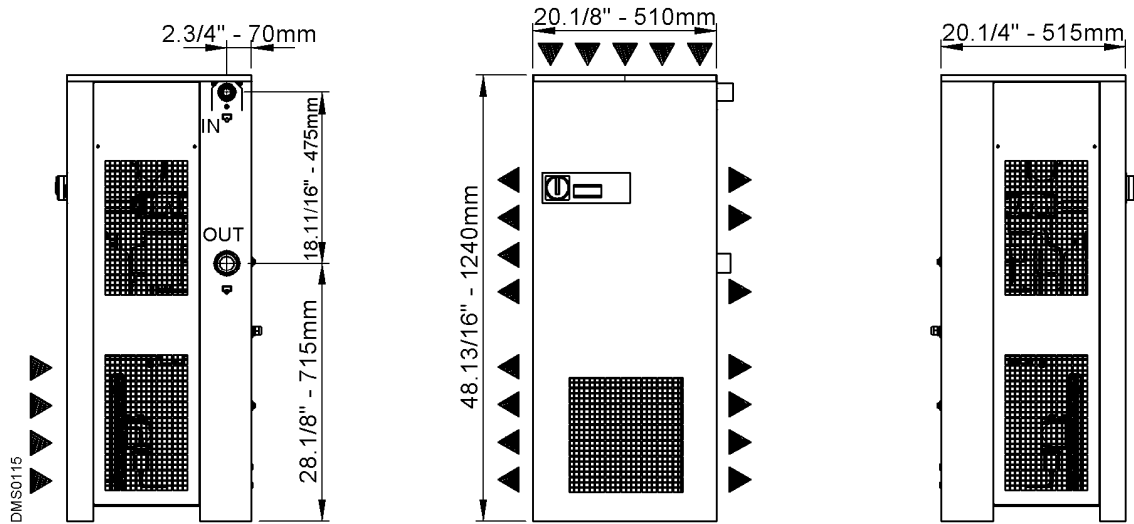

7.1.4. Dryers Dimensions DRYPOINT RA HT 200-250 NA

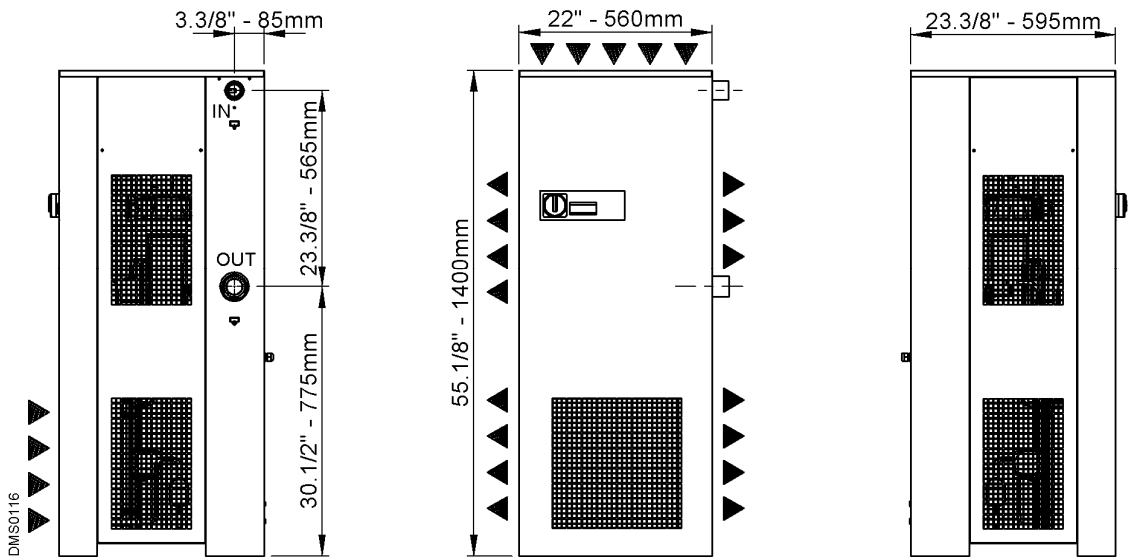

7.1.5. Dryers Dimensions DRYPOINT RA HT 300-350 NA

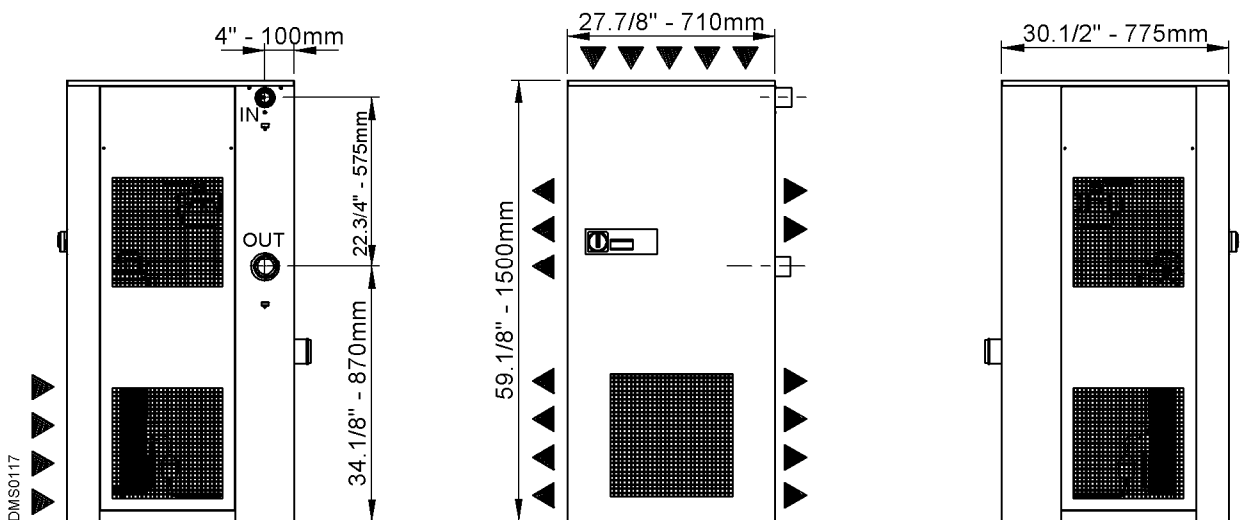

List of attachments

7.2. Exploded View

Exploded view table of components

① Alu-Dry Module	②① Bekomat drainer
1.1 Insulation Material	②② Main switch
② Refrigerant pressure-switch P _B (DRYPOINT RA HT 300-350 NA)	...
③ T _S safety thermo-switch (DRYPOINT RA HT 150-350 NA)	②⑥ Aftercooler
④ Refrigerant pressure-switch P _A (DRYPOINT RA HT NA 300-350)	②⑦ Aftercooler fan
⑤ Refrigerant pressure-switch (fan) P _V	27.1 Motor
⑥ Refrigerating compressor	27.2 Blade
⑦ Hot gas by-pass valve	27.3 Grid
⑧ Condenser (Air-Cooled)	②⑧ Pre-Filter
⑨ Condenser fan	...
9.1 Motor	⑤① Front panel
9.2 Blade	⑤② Back panel
9.3 Grid	⑤③ Right lateral panel
⑩ Filter Drier	⑤④ Left lateral panel
⑪ Capillary tube	⑤⑤ Cover
⑫ T1 Temperature probe (DewPoint)	⑤⑥ Base plate
⑬ Condensate drain service valve	⑤⑦ Upper plate
⑭ Y-shaped condensate drain strainer	⑤⑧ Support beam
⑮ Condensate drain solenoid valve	⑤⑨ Support bracket
⑯ Coil for cond. drain solenoid valve	⑥⑩ Control panel
⑰ Electronic control instrument	⑥① Electric connector
	...
	⑧① Flow diagram sticker

7.2.1. Exploded view DRYPOINT RA HT 20-50 NA

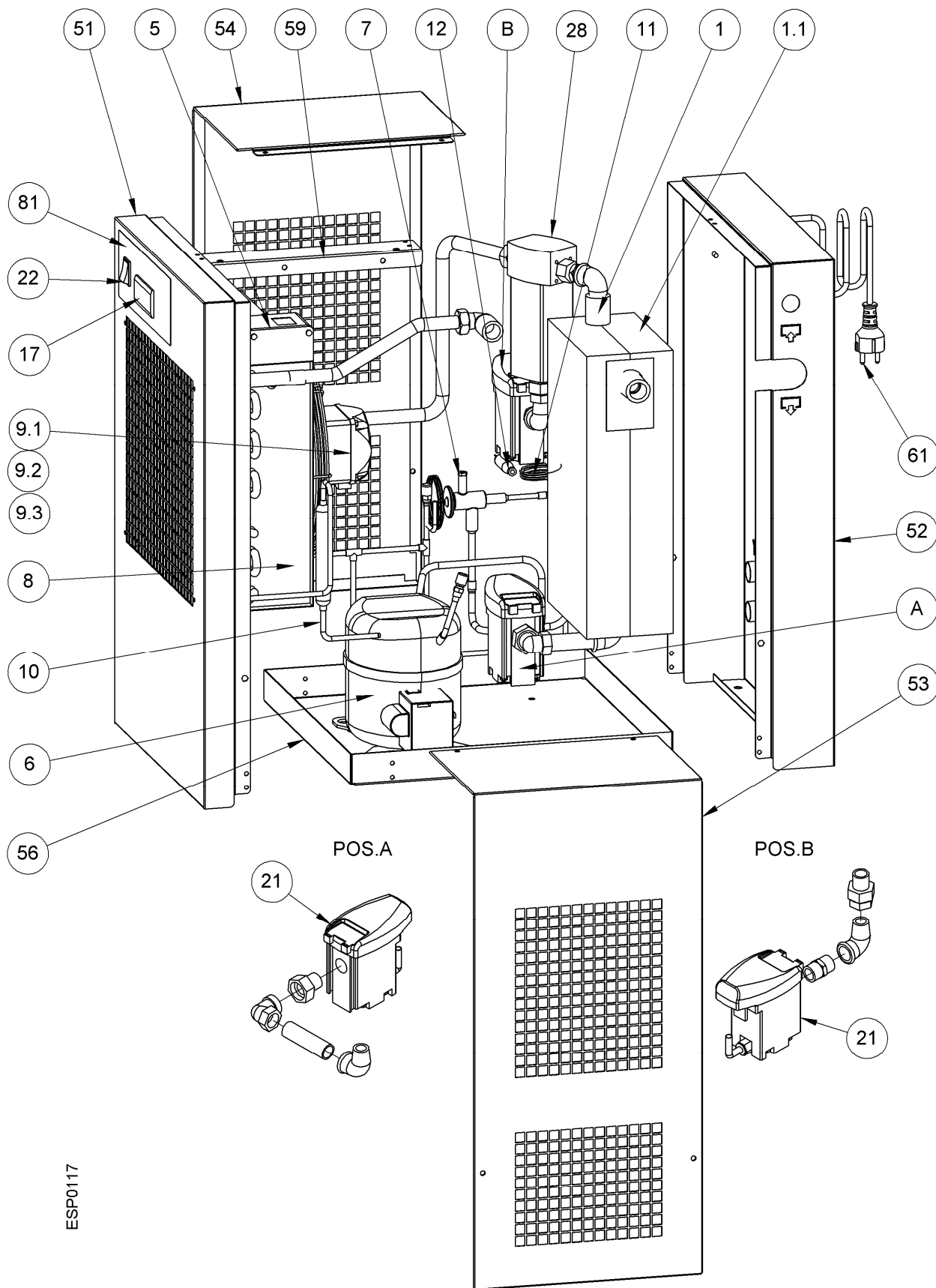

ESP0117

7.2.3. Exploded view DRYPOINT RA HT 100 NA

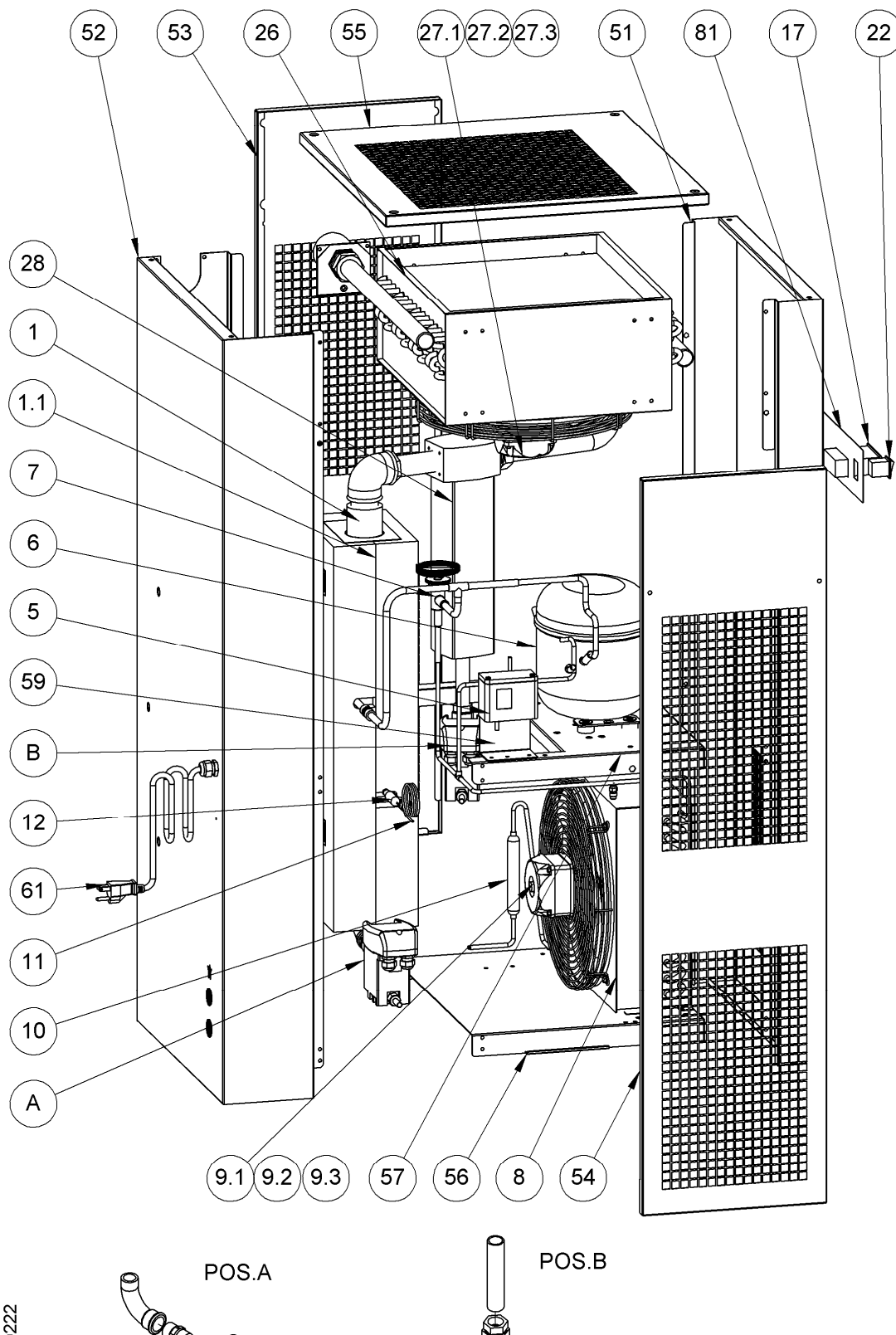

7.2.5. Exploded view DRYPOINT RA HT 200-250 NA

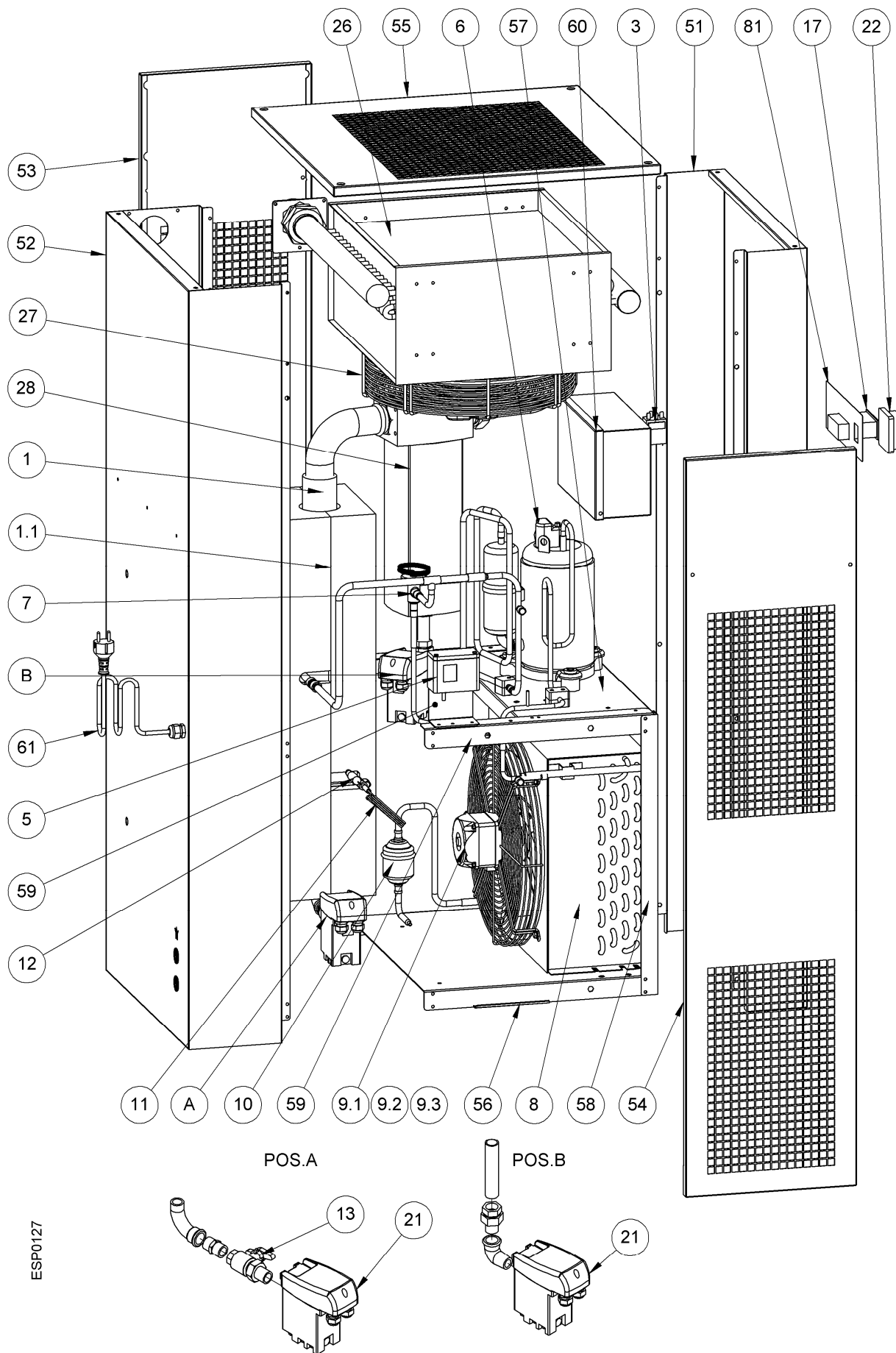

ESP0127

List of attachments

7.2.6. Exploded view DRYPOINT RA HT 300-350 NA

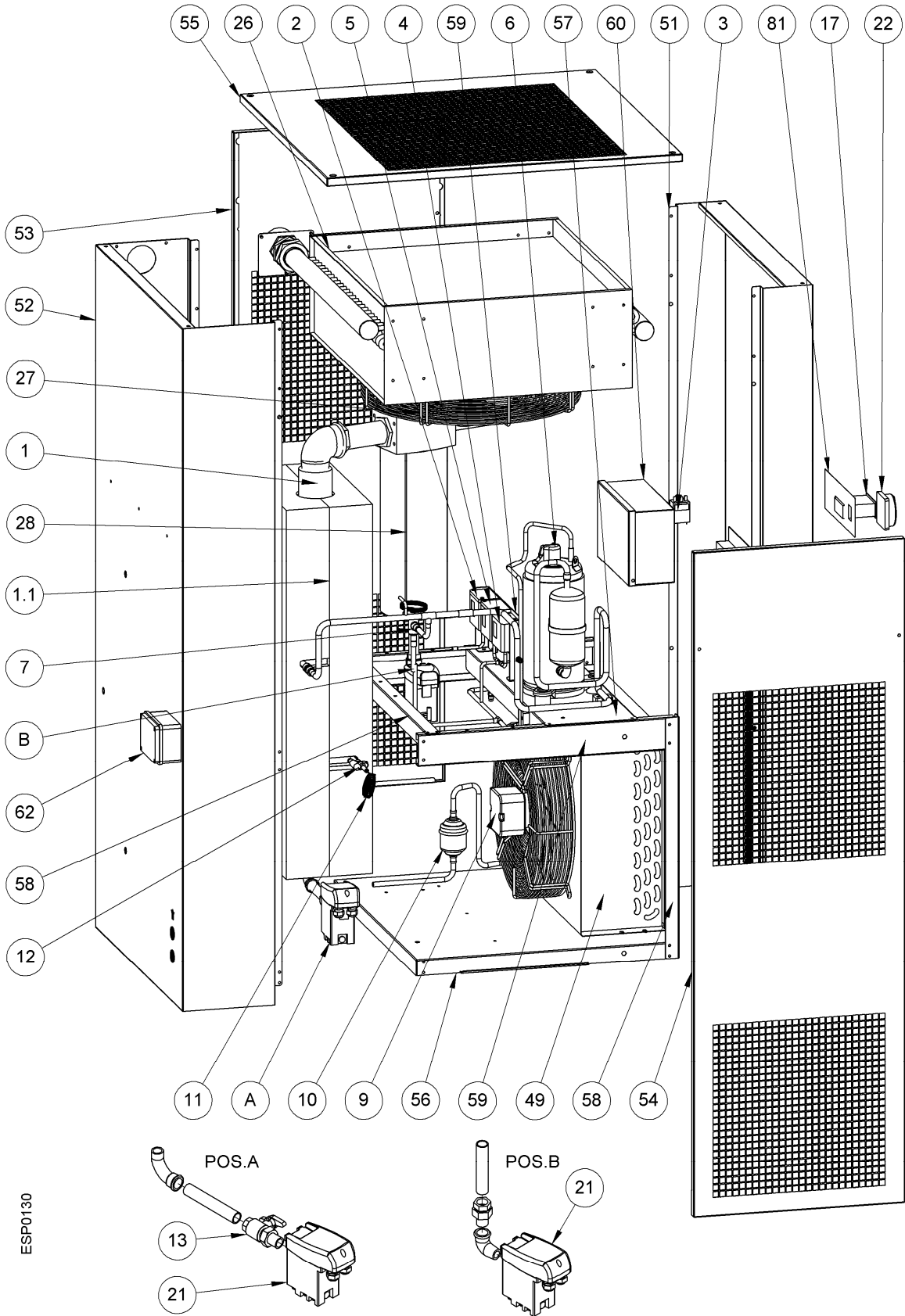

7.3. Electrical Diagram

Electrical Diagram table of components

- IG** : Main switch
- K** : Refrigerating compressor
 - KT** : Compressor thermal protection
 - KR** : Compressor starting relay (if installed)
 - CS** : Compressor starting capacitor (if installed)
 - CR** : Compressor run capacitor (if installed)
- V** : Condenser fan
 - CV** : Fan starting capacitor (if installed)
- DMC14** : DMC14 Electronic Instrument - Air Dryer Controller
- PR** : Temperature probe (DewPoint)
- PV** : Pressure switch - Fan control
- PA** : Pressure switch (high-pressure) - Compressor discharge side (DRYPOINT RA HT 300-350 NA)
- PB** : Pressure switch (low-pressure) - Compressor suction side (DRYPOINT RA HT 300-350 NA)
- TS** : Safety thermo switch (DRYPOINT RA HT 150-350 NA)
- BOX** : Electric supply box
- ELD** : Bekomat drainer

- BN = BROWN
- BU = BLUE
- BK = BLACK
- YG = YELLOW/GREEN

7.3.1. Electrical Diagram DRYPOINT RA HT 20-50 P (115/1/60) NA

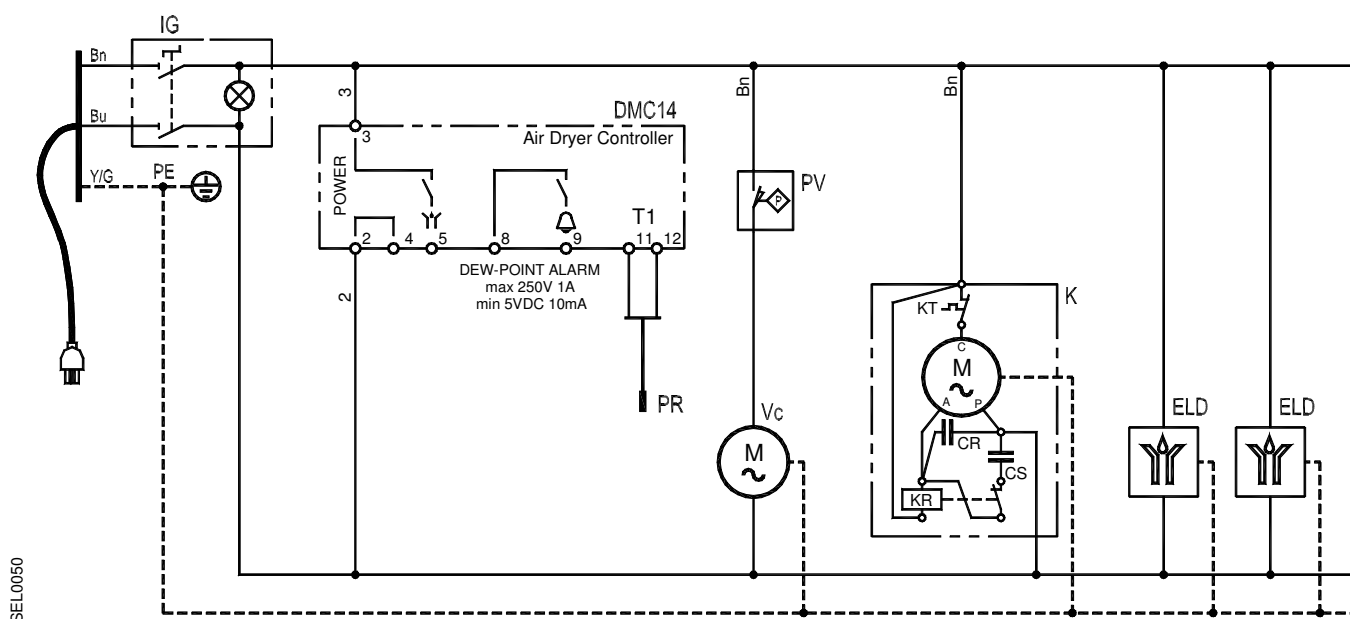

List of attachments

7.3.2. Electrical Diagram DRYPOINT RA HT 20-50 E (230/1/60) NA

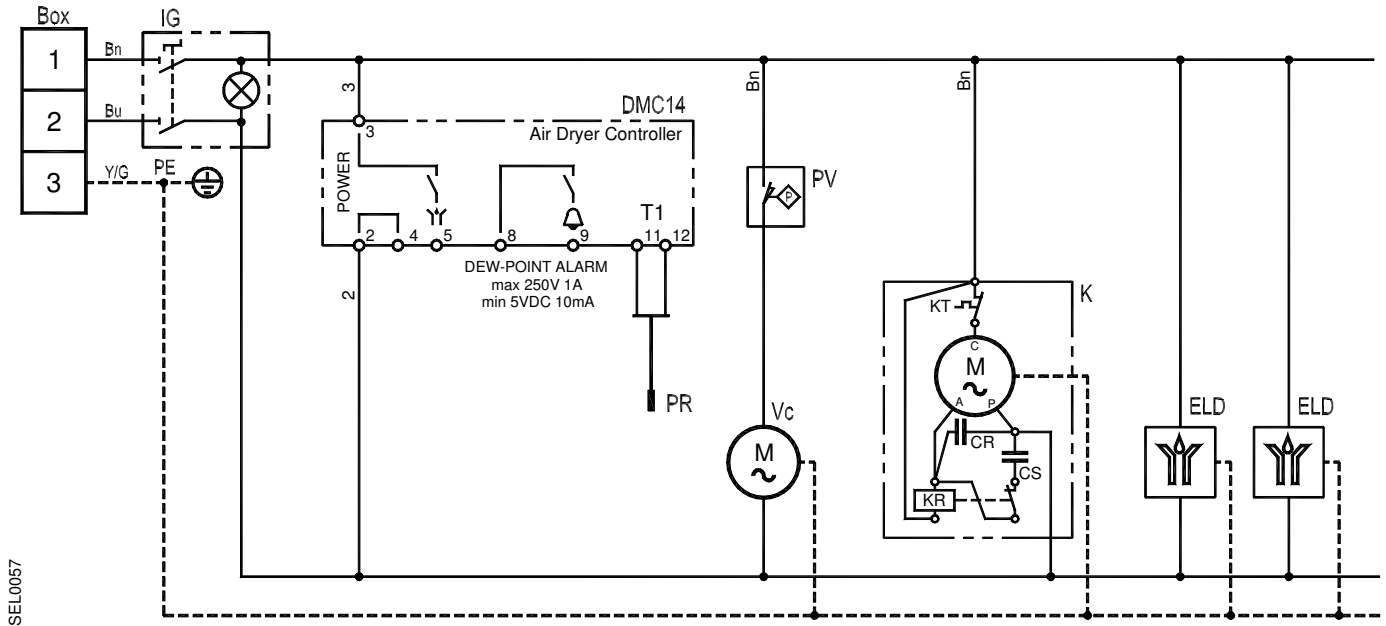

7.3.3. Electrical Diagram DRYPOINT RA HT 75-100 P (115/1/60) NA

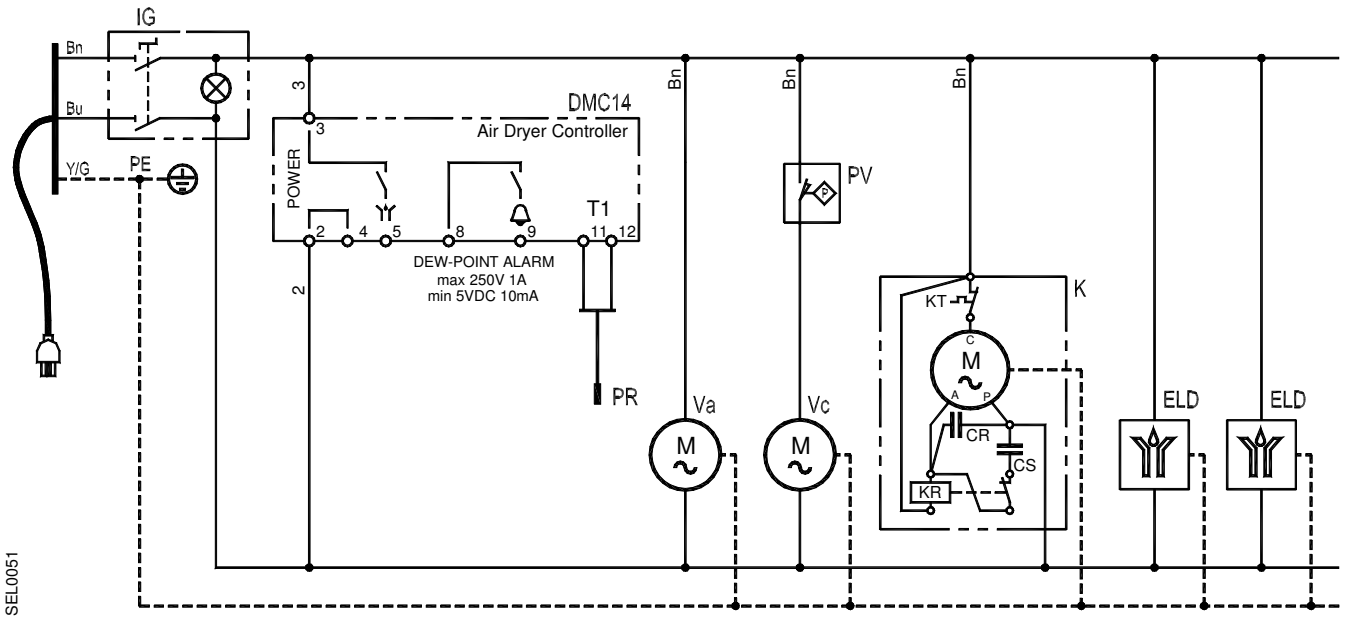

List of attachments

7.3.6. Electrical Diagram DRYPOINT RA HT 150-250 E (230/1/60) NA

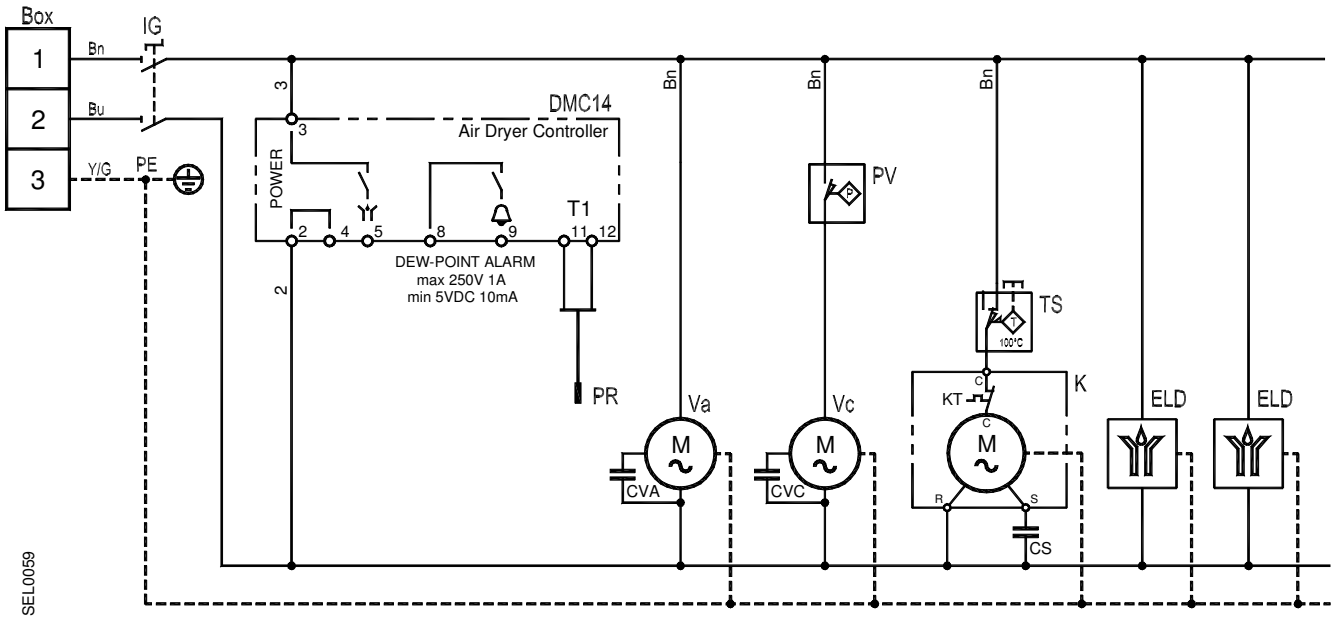

7.3.7. Electrical Diagram DRYPOINT RA HT 300-350 E (230/1/60) NA

