

**Operating manual  
Maintenance manual  
Spare parts**

**Refrigerating air dryer**

**DRYPOINT® RA 10-100 NA**

Dear Customer,  
 thank you for choosing our product. In order to get the best performances out of this product, please read this manual carefully.

To avoid incorrect operation of the equipment and possible physical risk to the operator, please read and strictly follow the instructions contained in this manual.

Note, these instructions are in addition to the safety rules that apply in the country where the dryer is installed. Before packing for shipment each **DRYPOINT RA NA** series refrigerated air dryer undergoes a rigorous test to ensure the absence of any manufacturing faults and to demonstrate that the device can perform all the functions for which it has been designed.

Once the dryer has been properly installed according to the instructions in this manual, it will be ready for use without any further adjustment. The operation is fully automatic, and the maintenance is limited to few controls and some cleaning operations, as detailed in the following chapters.

This manual must be maintained available in any moment for future references and it has to be intended as inherent part of the relevant dryer.

Due to the continuous technical evolution, we reserve the right to introduce any necessary change without giving previous notice.

Should you experience any trouble, or for further information, please do not hesitate to contact us.

## DATA NAMEPLATE

The data nameplate is located on the back of the dryer and shows all the primary data of the machine. Upon installation, fill in the table on the previous page with all the data shown on the data nameplate. This data should always be referred to when calling the manufacturer or distributor.

The removal or alteration of the data nameplate will void the warranty rights.

Model	⇒
Product key	⇒
Serial n°	⇒
Nominal Flow Rate	⇒
Working pressure PS min/max	⇒
Inlet temperature TS max	⇒
Ambient Temp.	⇒
Refrigerant	⇒
Refrig. Design Pres. HP/LP	⇒
Power supply	⇒
Electric Nominal Power	⇒
Fuse Max.	⇒

DRYPOINT RA	
Product key: Produktschlüssel:	<input type="text"/>
Serial n° / year of building: Serienr. / Baujahr:	<input type="text"/>
Nominal flow rate (ISO1217): Nemmvolumenstrom (ISO1217):	<input type="text"/> scfm
Working pressure PS min/max: Betriebsüberdruck PS min/max:	<input type="text"/> psig
Inlet temperature TS max: Eintrittstemperatur TS max:	<input type="text"/> °F
Ambient Temperature: Umgebungstemperatur:	<input type="text"/> °F
Refrigerant: Kältemittel:	<input type="text"/> type/oz
Refrig. Design Pres. HP/LP: Kältem. Auslegungsdruck HD/ND:	<input type="text"/> psig
Power supply: Elektrischer Anschluß:	<input type="text"/> V/ph/Hz
Electric Nominal Power: Elektrische Leistung:	<input type="text"/> W/A
Fuse protection max: Absicherung max:	<input type="text"/> A

TAD0011



**BEKO TECHNOLOGIES GMBH**  
 Im Taubental 7, 41468 Neuss  
 Germany  
<http://www.beko.de>

CE

1.	Safety rules.....	4
1.1.	Definition of the Conventional Signs Used in This Manual.....	4
1.2.	Warnings.....	5
1.3.	Proper Use of the Dryer.....	5
1.4.	Instructions for the use of pressure equipment according to PED Directive 97/23/EC.....	6
2.	Installation.....	6
2.1.	Transport.....	6
2.2.	Storage.....	6
2.3.	Installation site.....	7
2.4.	Installation layout.....	8
2.5.	Correction factors.....	9
2.6.	Connection to the Compressed Air System.....	10
2.7.	Electrical connections.....	11
2.8.	Condensate Drain.....	11
3.	Start up.....	11
3.1.	Preliminary Operations.....	11
3.2.	First start-up.....	12
3.3.	Start-up and shut down.....	12
4.	Technical Specifications.....	13
4.1.	Technical Specifications DRYPOINT RA 10-100 NA-P (115/1/60).....	13
4.2.	Technical Specifications DRYPOINT RA 10-100 NA-E (230/1/60).....	14
5.	Technical description.....	15
5.1.	Control panel.....	15
5.2.	Operation.....	15
5.3.	Flow Diagram.....	16
5.4.	Refrigerating compressor.....	16
5.5.	Condenser.....	17
5.6.	Filter Drier.....	17
5.7.	Capillary Tube.....	17
5.8.	Alu-Dry Module.....	17
5.9.	Hot Gas By-pass Valve.....	17
5.10.	DMC15 Electronic Instrument (Air Dryer Controller).....	18
5.11.	Electronic level controlled condensate drain BEKOMAT.....	19
6.	Maintenance, troubleshooting, spares and dismantling.....	20
6.1.	Controls and Maintenance.....	20
6.2.	Troubleshooting.....	21
6.3.	Spare Parts.....	23
6.4.	Maintenance operation on the refrigerating circuit.....	24
6.5.	Dismantling of the Dryer.....	24
7.	List of attachments.....	25
7.1.	Dryers Dimensions.....	25
7.1.1.	Dryers Dimensions DRYPOINT RA 10-15 NA.....	25
7.1.2.	Dryers Dimensions DRYPOINT RA 20-50 NA.....	25
7.1.3.	Dryers Dimensions DRYPOINT RA 75 NA.....	26
7.1.4.	Dryers Dimensions DRYPOINT RA 100 NA.....	26
7.2.	Exploded View.....	27
7.2.1.	Exploded view table of components DRYPOINT RA 10-100 NA.....	27
7.2.2.	Exploded view DRYPOINT RA 10-15 NA.....	28
7.2.3.	Exploded view DRYPOINT RA 20-35 NA.....	29
7.2.4.	Exploded view DRYPOINT RA 50 NA.....	30
7.2.5.	Exploded view DRYPOINT RA 75-100 NA.....	31
7.3.	Electrical Diagram.....	32
7.3.1.	Electrical Diagram table of components.....	32
7.3.2.	Electrical Diagram DRYPOINT RA 10-100 NA -P (115/1/60).....	33
7.3.3.	Electrical Diagram DRYPOINT RA 10-100 NA -P (230/1/60).....	33

## 1. Safety rules

### 1.1. Definition of the Conventional Signs Used in This Manual



Carefully read instruction manual before attempting any service or maintenance procedures on the dryer.



Caution warning sign. Risk of danger or possibility of damage to equipment, if related text is not followed properly.



Electrical hazard. Warning message indicates practices or procedures that could result in personal injury or fatality if not followed correctly.



Danger hazard. Part or system under pressure.



Danger hazard. High temperature conditions exist during operation of system. Avoid contact until system or component has dissipated heat.



Danger hazard. Treated air is not suitable for breathing purposes; serious injury or fatality may result if precautions are not followed.



Danger hazard: In case of fire, use an approved fire extinguisher, water is not an acceptable means in cases of fire.



Danger hazard. Do not operate equipment with panels removed.



Maintenance or control operation to be performed by qualified personnel only <sup>1</sup>.



Compressed air inlet connection point



Compressed air outlet connection point



Condensate drain connection point



Operations which can be performed by the operator of the machine, if qualified <sup>1</sup>.

**NOTE: Text that specifies items of note to be taken into account does not involve safety precautions.**



In designing this unit a lot of care has been devoted to environmental protection:

- CFC free refrigerants
- CFC free insulation parts
- Energy saving design
- Limited acoustic emission
- Dryer and relevant packaging composed of recyclable materials

This symbol requests that the user heed environmental considerations and abide with suggestions annotated with this symbol.

<sup>1</sup> Experienced and trained personnel familiar with national and local codes, capable to perform the needed activities, identify and avoid possible dangerous situations while handling, installing, using and servicing the machine. Ensuring compliance to all statutory regulations.

## 1.2. Warnings



### **DANGER!** **Compressed air!**

Compressed air is a highly hazardous energy source.

Never work on the dryer with pressure in the system.



Never point the compressed air or the condensate drain outlet hoses towards anybody.

The user is responsible for the proper installation of the dryer. Failure to follow instructions given in the "Installation" chapter will void the warranty. Improper installation can create dangerous situations for personnel and/or damages to the machine could occur.



### **DANGER!** **Mains voltage!**

Only qualified personnel are authorized to service electrically powered devices. Before attempting maintenance, the following conditions must be satisfied:

Ensure that main power is off, machine is locked out, tagged for service and power cannot be restored during service operations.

Ensure that valves are shut and the air circuit is at atmospheric pressure. De-pressurize the dryer.



### **CAUTION!** **Refrigerant!**

These refrigerating air dryers contain R134a or R404A HFC type refrigerant fluid. Refer to the specific paragraph - maintenance operation on the refrigerating circuit.



### **WARNING!** **Unauthorized interference!**

Warranty does not apply to any unit damaged by accident, modification, misuse, negligence or misapplication. Unauthorized alterations will immediately void the warranty.



In case of fire, use an approved fire extinguisher, water is not an acceptable means in cases of electrical fire.

## 1.3. Proper Use of the Dryer

This dryer has been designed, manufactured and tested for the purpose of separating the humidity normally contained in compressed air. Any other use has to be considered improper.

The Manufacturer will not be responsible for any problem arising from improper use; the user will bear responsibility for any resulting damage.

Moreover, the correct use requires the adherence to the installation instructions, specifically:

- Voltage and frequency of the main power.
- Pressure, temperature and flow-rate of the inlet air.
- Ambient temperature.

This dryer is supplied tested and fully assembled. The only operation left to the user is the connection to the plant in compliance with the instructions given in the following chapters.



### **WARNING!** **Improper use!**

The purpose of the machine is the separation of water and eventual oil particles present in compressed air.

The dried air cannot be used for breathing purposes or for operations leading to direct contact with foodstuff.



This dryer is not suitable for the treatment of dirty air or of air containing solid particles.

### 1.4. Instructions for the use of pressure equipment according to PED Directive 97/23/EC

To ensure the safe operation of pressure equipments, the user must conform strictly to the above directive and the following:

1. The equipment must only be operated within the temperature and pressure limits stated on the manufacturer's data nameplate.
2. Welding on heat-exchanger is not recommended.
3. The equipment must not be stored in badly ventilated spaces, near a heat source or inflammable substances.
4. Vibration must be eliminated from the equipment to prevent fatigue failure.
5. Automatic condensate drains should be checked for operation every day to prevent a build up of condensate in the pressure equipment.
6. The maximum working pressure stated on the manufacturer's data nameplate must not be exceeded. Prior to use, the user must fit safety / pressure relief devices.
7. All documentation supplied with the equipment (manual, declaration of conformity etc.) must be kept for future reference.
8. Do not apply weights or external loads on the vessel or its connecting piping.



#### **WARNING!**

#### **Unauthorized interference!**

Users of the equipment must comply with all local and national pressure equipment legislation in the country of installation.

## 2. Installation

### 2.1. Transport

Check for visible loss or damage, if no visible damage is found place the unit near to the installation point and unpack the contents.

- Always keep the dryer in the upright vertical position. Damage to components could result if unit is laid on its side or if placed upside down.
- Store machine in a clean, dry environment, do not expose to severe weather environments.
- Handle with care. Heavy blows could cause irreparable damage.

### 2.2. Storage

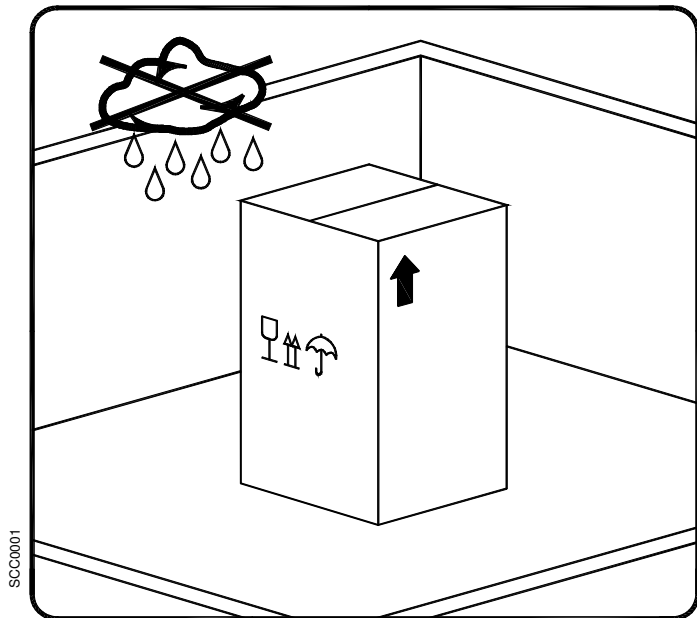

Even when packaged, keep the machine protected from severity of the weather.

Keep the dryer in vertical position, also when stored. Turning it upside down some parts could be irreparably damaged.

If not in use, the dryer can be stored in its packaging in a dust free and protected site at a maximum temperature of 115°F (45°C), and a specific humidity not exceeding 90%. Should the stocking time exceed 12 months, please contact the manufacturer.



The packaging materials are recyclable. Dispose of material in compliance with the rules and regulations in force in the destination country.

### 2.3. Installation site



**CAUTION!**  
**Ambient conditions!**

Failure to install dryer in the proper ambient conditions will affect the dryer's ability to condense refrigerant gas. This can cause higher loads on the compressor, loss of dryer efficiency and performance, overheated condenser fan motors, electrical component failure and dryer failure due to the following: compressor loss, fan motor failure and electrical component failure. Failures of this type will affect warranty considerations. Do not install dryer in an environment of corrosive chemicals, explosive gasses, poisonous gasses; steam heat, areas of high ambient conditions or extreme dust and dirt.



In case of **fire**, use an approved fire extinguisher, **water** is not an acceptable means in cases of fire.

**Minimum installation requirements:**

- Select a clean room dry, free from dust, and protected from atmospheric disturbances.
- The supporting area must be smooth, horizontal and able to hold the weight of the dryer.
- Minimum ambient temperature +34 °F (+1 °C).
- Maximum ambient temperature +115 °F (+45 °C).
- Leave at least 40 in (1m) of free space on every side of the drier for ventilation purposes and maintenance operations.

The dryer doesn't require to be fixed to the supporting surface. The dryer needs to be fixed to the supporting surface only with particular installation procedures (dryer on brakets, hanging units, etc.)

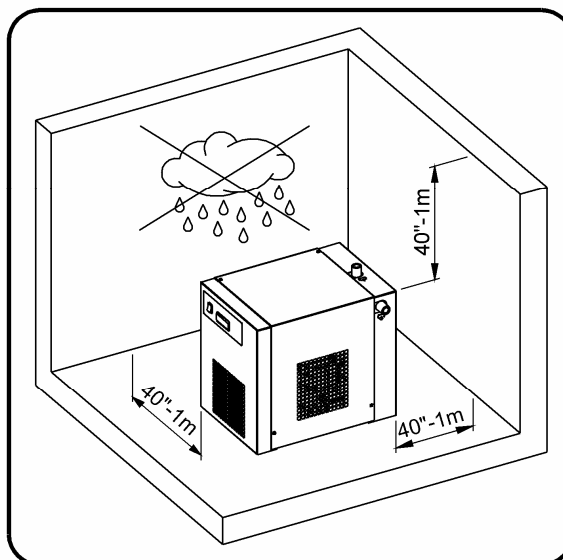

**Dryer hanging:**

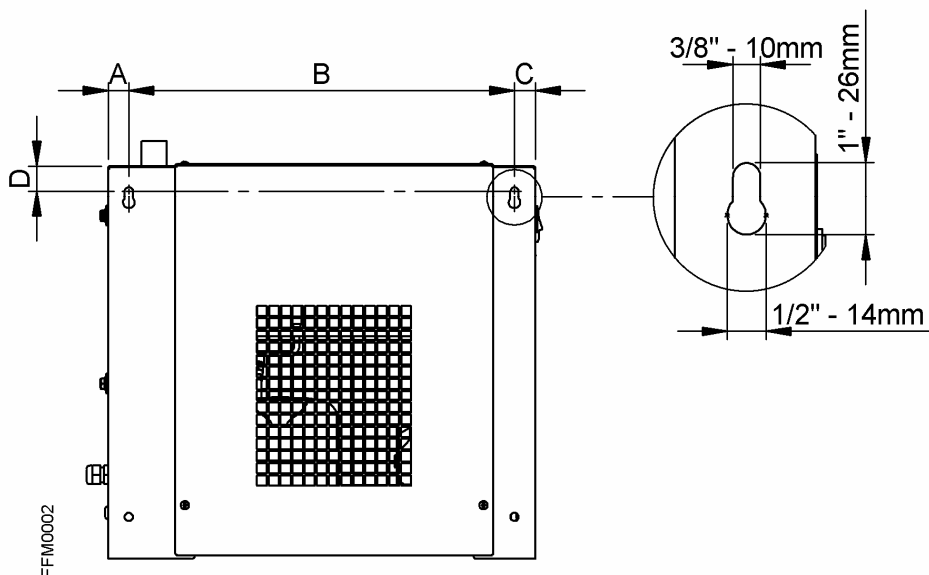

FFM0002

Dryer	A [in-mm]	B [in-mm]	C [in-mm]	D [in-mm]
DRYPOINT RA 10-15 NA	3/4"- 20	12 - 305	3/4"- 20	1.1/4" - 33
DRYPOINT RA 20-50 NA	1"- 25	18.5/16"- 465	1"- 25	13/16" - 30
DRYPOINT RA 75 NA	1.9/16"- 40	14.3/16"- 360	3/4"- 20	13/16" - 30
DRYPOINT RA 100 NA	1.9/16"- 40	15,3/16"- 385	3/4"- 20	13/16" - 30

## 2.4. Installation layout

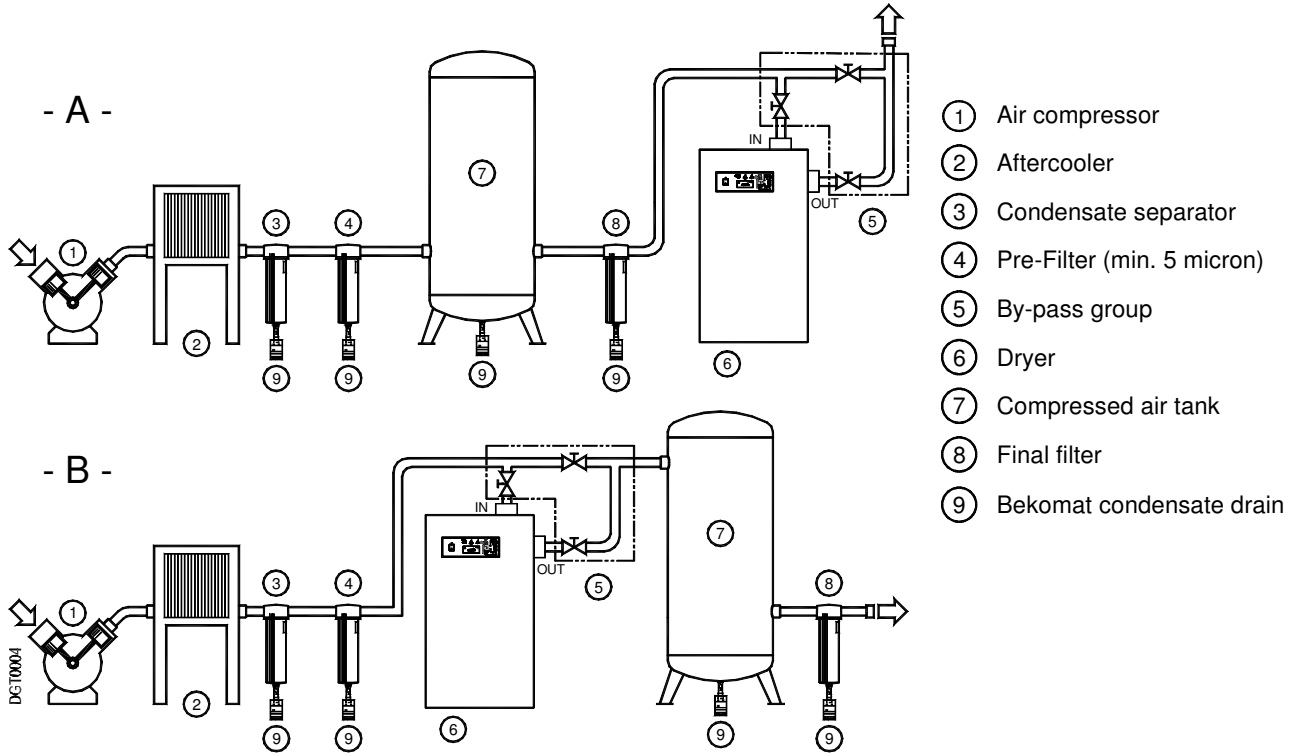

### CAUTION! Polluted inlet air!

In case of heavily polluted inlet air (ISO 8573.1 class 3.-3 or worse quality), we recommend the additional installation of a pre-filter (f.e. CLEARPOINT F040) to prevent a clogging of the heat exchanger

**Type A** installation is suggested when the compressor operates at reduced intermittence and the total consumption equals the compressor flow rate.

**Type B** installation is suggested when the air consumption can consistently change with peak values highly exceeding the flow rate of the compressor. The capacity of the tank must be sized in order to compensate eventual instantaneous demand conditions (peak air consumption).

## 2.5. Correction factors

Correction factor for operating pressure changes :									
Inlet air pressure	psig	60	80	100	120	140	160	180	200
	barg	4	5	7	8	10	11	12.5	14
Factor (F1)		0.79	0.91	1.00	1.07	1.13	1.18	1.23	1.27

Correction factor for ambient temperature changes (Air-Cooled):							
Ambient temperature	°F	≤ 80	90	100	105	110	115
	°C	≤ 27	32	38	40	43	45
Factor (F2)		1.12	1.09	1.00	0.93	0.85	0.75

Correction factor for inlet air temperature changes:						
Air temperature	°F	≤ 90	100	110	120	130
	°C	≤ 32	38	43	50	55
Factor (F3)		1.18	1.00	0.84	0.69	0.55

Correction factor for DewPoint changes:					
DewPoint	°F	38	41	45	50
	°C	3	5	7	10
Factor (F4)		0.92	1.00	1.10	1.25

### How to find the air flow capacity:

$$\text{Air flow capacity} = \text{Nominal duty} \times \text{Factor (F1)} \times \text{Factor (F2)} \times \text{Factor (F3)} \times \text{Factor (F4)}$$

#### Example:

An **DRYPOINT RA 75 NA** has a nominal duty of **75 scfm (127 m<sup>3</sup>/h)**. What is the maximum allowable flow through the dryer under the following operating conditions:

- Inlet air pressure = 120 psig (8 barg)
- Ambient temperature = 90°F (32°C)
- Inlet air temperature = 110°F (43°C)
- Pressure DewPoint = 41°F (5°C)

Each item of data has a corresponding numerical factor as follows:

$$\text{Air flow capacity} = 75 \times 1.07 \times 1.09 \times 0.81 \times 1.00$$

= **71 scfm (120 m<sup>3</sup>/h)** → This is the maximum flow rate that the dryer can accept under these operating conditions.

### How to select a suitable dryer for a given duty:

$$\text{Minimum Std. air flow rate} = \text{Design air flow} \div \text{Factor (F1)} \div \text{Factor (F2)} \div \text{Factor (F3)} \div \text{Factor (F4)}$$

#### Example:

The procedure here is to list the operating conditions and then to locate the corresponding numerical factors:

- Design air flow = 60 scfm (102 m<sup>3</sup>/h)
- Inlet air pressure = 120 psig (8 barg)
- Ambient temperature = 90°F (32°C)
- Inlet air temperature = 110°F (43°C)
- Pressure DewPoint = 41°F (5°C)

In order to select the correct dryer model the required flow rate is to be divided by the correction factors relating to above mentioned parameters:

$$\text{Minimum Std. air flow rate} = 60 \div 1.07 \div 1.09 \div 0.81 \div 1.00$$

= **64 scfm (109 m<sup>3</sup>/h)** → Therefore the model suitable for the conditions above is **DRYPOINT RA 75 NA** (75 scfm or 127 m<sup>3</sup>/h - nominal duty).

## 2.6. Connection to the Compressed Air System



**DANGER!**

**Compressed air!**

Operations to be performed by qualified personnel only.  
Never work on compressed air system under pressure.



The user is responsible to ensure that the dryer will never be operated with pressure exceeding the maximum pressure rating on the unit data tag.

Over-pressurizing the dryer could be dangerous for both the operator and the unit.

The air temperature and the flow entering the dryer must comply within the limits stated on the data nameplate. The system connecting piping must be kept free from dust, rust, chips and other impurities, and must be consistent with the flow-rate of the dryer. In case of treatment of air at particularly high temperature, the installation of a final refrigerator could result necessary. In order to perform maintenance operations, it recommended that a dryer by-pass system be installed as shown in the following illustration.

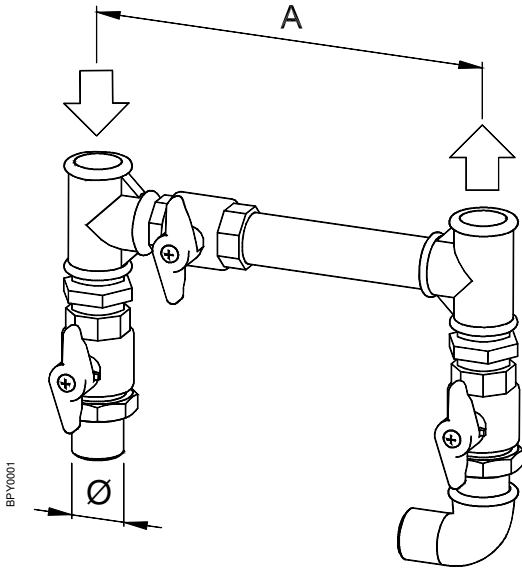

Dryer	Ø [NPT-F]	A [in - mm]
DRYPOINT RA 10-15 NA	3/8"	1.5/8" - 40
DRYPOINT RA 20-50 NA	1/2"	8.1/4" - 210
DRYPOINT RA 75 NA	1"	8" - 205
DRYPOINT RA 100 NA	1.1/4"	8" - 205

In realising the dryer, particular measures have been taken in order to limit the vibration which could occur during the operation. Therefore we recommend to use connecting pipes able to insulate the dryer from possible vibrations originating from the line (flexible hoses, vibration damping fittings, etc.).

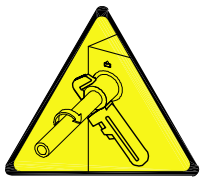

**CAUTION:**

Piping the dryer, inlet/outlet connections must be supported as show in the diagram.  
Failing will result in damage.

## 2.7. Electrical connections



### **DANGER!**

#### **Supply voltage!**

Qualified personnel should carry out connecting unit to the main power.

Be sure to check the local codes in your area.

Before connecting the unit to the electrical supply, verify the identification plate for the proper electrical information. Voltage tolerance is +/- 5%.

Dryer supplied at 115/1/60 voltage comes with a mains connecting cable already installed and ending with a North-American standard plug 2 poles + ground. Dryer supplied at 230/1/60 voltages comes with a box for the connection to the mains.

Be sure to provide the proper fuses or breakers based on the data information located on the nameplate.

The mains socket must be provided with a **mains magneto-thermal differential breaker** ( $\Delta n=0.03A$ ), adjusted on the basis of the consumption of the dryer (see the nominal values on the data plate of the dryer). The cross section of the power supply cables must comply with the consumption of the dryer, while keeping into account also the ambient temperature, the conditions of the mains installation, the length of the cables, and the requirements enforced by the local Power Provider.



### **DANGER!**

#### **Mains voltage and missing earthing!**

Important: ensure that the plant is earthed.

Do not use any socket adapters at the mains plug.

If the mains plug needs to be replaced, this must only be done by a qualified electrician

## 2.8. Condensate Drain



### **DANGER!**

#### **Compressed air and pressurized condensate!**

The condensate is discharge at the system pressure.

Drain line should be secured.



Never point the condensate drain line towards anybody.

### **DRYPOINT RA 10-35 NA**

The condensate drain occurs through a solenoid valve protected with a mechanical strainer. The solenoid valve coil is operated by electronic instrument.

### **DRYPOINT RA 50-100 NA**

The dryer comes already fitted with an electronically level controlled BEKOMAT condensate drain.

**Connect and properly fasten the condensate drain to a collecting plant or container.**

**The drain cannot be connected to pressurized systems.**



Don't dispose the condensate in the environment.

The condensate collected in the dryer contains oil particles released in the air by the compressor.

Dispose the condensate in compliance with the local rules.

We suggest to install a water-oil separator where to convey all the condensate drain coming from compressors, dryers, tanks, filters, etc. We recommend ÖWAMAT oil-water separators for disperse compressor condensate, BEKOSPLIT emulsion splitters for emulsified condensate.

## 3. Start up

### 3.1. Preliminary Operations



### **CAUTION!**

#### **Exceeding of operating parameters!**

Verify that the operating parameters match with the nominal values stated on the data nameplate of the dryer (voltage, frequency, air pressure, air temperature, ambient temperature, etc.).

This dryer has been thoroughly tested, packaged and inspected prior to shipment. Nevertheless, the unit could be damaged during transportation, check the integrity of the dryer during first start-up and monitor operation during the first hours of operation.



Qualified personnel must perform the first start-up.

When installing and operating this equipment, comply with all National Electrical Code and any applicable federal, state and local codes.



Who is operating the unit is responsible for the proper and safe operation of the dryer.

Never operate equipment with panels removed.

### 3.2. First start-up



This procedure should be followed on first start-up, after periods of extended shutdown or following maintenance procedures.

Qualified personnel must perform the start-up.

#### Sequence of operations (refer to paragraph 5.1 Control Panel).

- Ensure that all the steps of the “Installation” chapter have been observed.
- Ensure that the connection to the compressed air system is correct and that the piping is suitably fixed and supported.
- Ensure that the condensate drain pipe is properly fastened and connected to a collection system or container.
- Ensure that the by-pass system (if installed) is open and the dryer is isolated
- Ensure that the manual valve of the condensate drain circuit is open.
- Remove any packaging and other material which could obstruct the area around the dryer.
- Activate the mains switch.
- Turn on the main switch - pos. 1 on the control panel.
- Ensure that the DMC15 electronic instrument is ON.
- Ensure the consumption matches with the values of the data plate.
- Ensure the fan work properly - wait for its first interventions.
- Allow the dryer temperature to stabilise at the pre-set value.
- Slowly open the air inlet valve.
- Slowly open the air outlet valve.
- Slowly close the central by-pass valve of the system (if installed).
- Check the piping for air leakage.
- Ensure the drain is regularly cycling - wait for its first interventions.

### 3.3. Start-up and shut down



#### Start-up (refer to paragraph 5.1 Control Panel)

- Check the condenser for cleanliness.
- Verify that the system is powered.
- Turn on the main switch - pos. 1 on the control panel.
- Ensure that DMC15 electronic instrument is ON.
- Wait a few minutes; verify that the DewPoint temperature displayed on DMC15 electronic instrument is correct and that the condensate is regularly drained.
- Switch on the air compressor.



#### Shut down (refer to paragraph 5.1 Control Panel)

- Verify that the DewPoint temperature displayed on electronic controller DMC15 is correct.
- Shut down the air compressor.
- After a few minutes, Shut down the dryer using the main switch on the control panel (pos. 1).

**NOTE : A DewPoint included in the green operating area of the electronic controller is correct according to the possible working conditions (flow-rate, temperature of the incoming air, ambient temperature, etc.)**

During the operation, the refrigerating compressor will run continuously. The dryer must remain on during the full usage period of the compressed air, even if the air compressor works intermittently.



The **number of starts must be no more than 6 per hour**. The dryer must stop running for at least 5 minutes before being started up again.

The user is responsible for compliance with these rules. Frequent starts may cause irreparable damage.

## 4. Technical Specifications

### 4.1. Technical Specifications DRYPOINT RA 10-100 NA-P (115/1/60)

DRYPOINT RA NA MODEL	10 - P	15 - P	20 - P	35 - P	50 - P	75 - P	100 - P
Air flow rate at nominal condition <sup>1</sup>							
[scfm]	10	15	20	35	50	75	100
[m <sup>3</sup> /h]	17	25	34	59	85	127	170
[l/min]	283	425	566	991	1415	2123	2830
Pressure DewPoint at nominal condition <sup>1</sup>	41 - 5						
[°F - °C]							
Nominal (max.) ambient temperature	100 (115) - 38 (45)						
[°F - °C]							
Min. ambient temperature	34 - 1						
[°F - °C]							
Nominal (max.) inlet air temperature	100 (130) - 38 (55)						
[°F - °C]							
Nominal inlet air pressure	100 - 7						
[psig - barg]							
Max. inlet air pressure	230 - 16						
[psig - barg]							
Air pressure drop - Δp	1.5 - 0.10	2.0 - 0.14	0.6 - 0.04	1.3 - 0.09	2.2 - 0.15	2.6 - 0.18	2.2 - 0.15
[psi - bar]							
Inlet - Outlet connections	3/8"			1/2"		1"	
[NPT-F]							
Refrigerant type	R 134.a						
Refrigerant quantity <sup>2</sup>	7.1/4 - 200		7.1/2 - 210		8.3/4 - 250		15.1/2 - 440
[oz - kg]							
Cooling air flow	180 - 300						
[cfm - m <sup>3</sup> /h]							
Heat load	1690						
[Btu/h]							
Standard Power Supply <sup>2</sup>	115/1/60						
Nominal electric absorption	190	200	210	290	300	450	700
[W]							
Max. electric absorption	230	240	250	340	390	510	830
[W]							
Max. level noise at 401in (1m)	< 70						
[dba]							
Weight	46 - 21	48 - 22	55 - 25	62 - 28	70 - 32	75 - 34	86 - 39
[lbs - kg]							

<sup>1</sup> The nominal condition refers to an ambient temperature of 100°F (38°C) with inlet air at 100psig (7barg) and 100°F (38°C).

<sup>2</sup> Check the data shown on the identification plate.

**4.2. Technical Specifications DRYPOINT RA 10-100 NA-E (230/1/60)**

<b>DRYPOINT RA NA MODEL</b>	<b>10 - E</b>	<b>15 - E</b>	<b>20 - E</b>	<b>35 - E</b>	<b>50 - E</b>	<b>75 - E</b>	<b>100 - E</b>
Air flow rate at nominal condition <sup>1</sup>	10	15	20	35	50	75	100
	[scfm]						
	17	25	34	59	85	127	170
	[m <sup>3</sup> /h]						
	283	425	566	991	1415	2123	2830
	[l/min]						
Pressure DewPoint at nominal condition <sup>1</sup>	41 – 5						
	[°F – °C]						
Nominal (max.) ambient temperature	100 (115) – 38 (45)						
	[°F – °C]						
Min. ambient temperature	34 – 1						
	[°F – °C]						
Nominal (max.) inlet air temperature	100 (130) – 38 (55)						
	[°F – °C]						
Nominal inlet air pressure	100 – 7						
	[psig – barg]						
Max. inlet air pressure	230 - 16						
	[psig – barg]						
Air pressure drop - Δp	1.5 – 0.10	2.0 – 0.14	0.6 – 0.04	1.3 – 0.09	2.2 – 0.15	2.6 – 0.18	2.2 – 0.15
	[psi – bar]						
Inlet - Outlet connections	3/8"			1/2"		1"	1.1/4"
	[NPT-F]						
Refrigerant type	R 134.a						
Refrigerant quantity <sup>2</sup>	7.1/4 – 200	7.1/2 – 210		7.3/4 – 220	8.3/4 – 250	11.1/2 – 330	15.1/2 – 440
	[oz – kg]						
Cooling air flow	180 – 300						
	[cfm – m <sup>3</sup> /h]						
Heat load	1690						
	[Btu/h]						
Standard Power Supply <sup>2</sup>	230/1/60						
	[PhV/Hz]						
Nominal electric absorption	190	200	210	290	300	500	700
	[W]						
Max. electric absorption	1.1	1.2	1.2	1.6	1.7	2.7	4.0
	[A]						
Max. electric absorption	230	240	250	340	390	660	830
	[W]						
Max. level noise at 401in (1m)	1.2	1.3	1.4	1.8	2.0	3.3	4.3
	[A]						
Max. level noise at 401in (1m)	< 70						
	[dba]						
Weight	46 - 21	48 - 22	55 - 25	62 - 28	70 - 32	75 - 34	86 - 39
	[lbs – kg]						

<sup>1</sup> The nominal condition refers to an ambient temperature of 100°F (38°C) with inlet air at 100psig (7barg) and 100°F (38°C).

<sup>2</sup> Check the data shown on the identification plate.

## 5. Technical description

### 5.1. Control panel

The control panel illustrated below is the only dryer-operator interface.

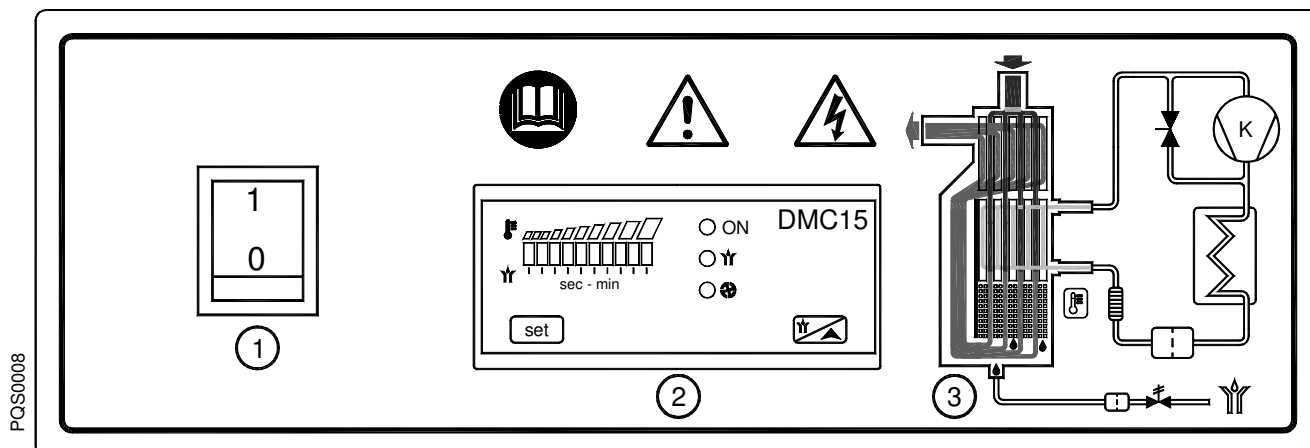

- ① Main switch
- ② DMC15 Electronic control instrument
- ③ Air and refrigerating gas flow diagram

### 5.2. Operation

**Operating principal** - The dryer models described in this manual operate all on the same principal. The hot moisture laden air enters an air to air heat exchanger. The air then goes through the evaporator, also known as the air to refrigerant heat exchanger. The temperature of the air is reduced to approximately 36°F (2°C), causing water vapor to condense to liquid. The liquid is continuously coalesced and collected in the separator for removal by the condensate drain. The cool moisture free air then passes back through the air to air heat exchanger to be reheated to within 8 degrees of the incoming air temperature as it exits the dryer.

**Refrigerant circuit** - Refrigerant gas is cycled through the compressor and exits at high pressure to a condenser where heat is removed causing the refrigerant to condense to a high-pressure liquid state. The liquid is forced through a capillary tube where the resulting pressure drop allows the refrigerant to boil off at a predetermined temperature. Low-pressure liquid refrigerant enters the heat exchanger where heat from the incoming air is transferred causing the refrigerant to boil; the resulting phase change produces a low pressure, low temperature gas. The low-pressure gas is returned to the compressor, where it is re-compressed and begins the cycle again. During those periods when the compressed air load is reduced the excess refrigerant is by-passed automatically back to the compressor via the Hot Gas By-pass Valve circuit.

5.3. Flow Diagram

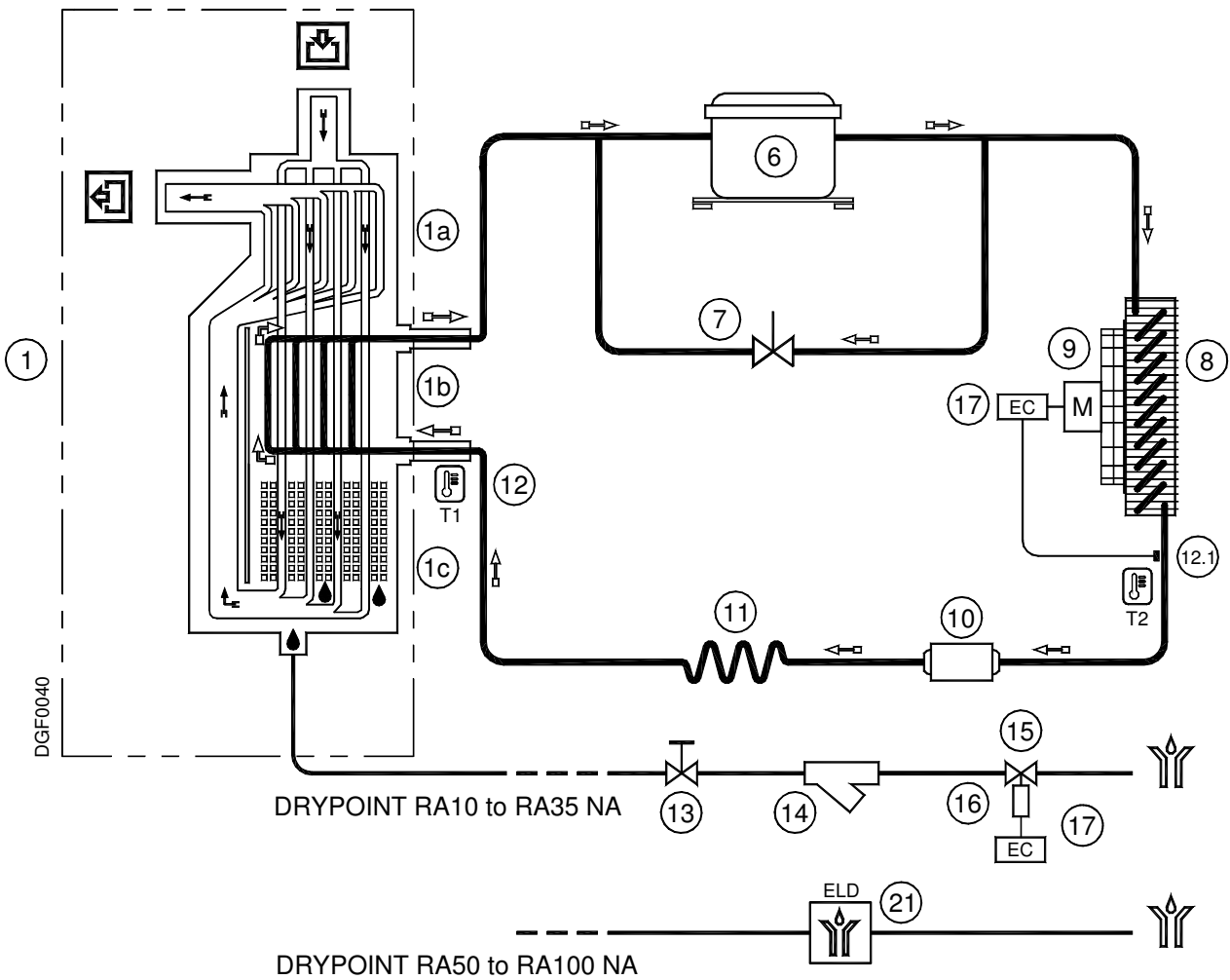

- |  |  |
|--|--|
| <ul style="list-style-type: none"> <li>① Alu-Dry Module</li> <li style="padding-left: 20px;">a - Air-to-air heat exchanger</li> <li style="padding-left: 20px;">b - Air-to-refrigerant exchanger</li> <li style="padding-left: 20px;">c - Condensate separator</li> <li>...</li> <li>⑥ Refrigerating compressor</li> <li>⑦ Hot Gas By-pass Valve</li> <li>⑧ Condenser (Air-Cooled)</li> <li>⑨ Condenser fan</li> <li>⑩ Filter Drier</li> </ul> | <ul style="list-style-type: none"> <li>⑪ Capillary tube</li> <li>...</li> <li>⑫ T1 Temperature probe (DewPoint)</li> <li>⑫.1 T2 Temperature probe (fan control)</li> <li>⑬ Condensate drain service valve</li> <li>⑭ Y-shaped condensate drain strainer</li> <li>⑮ Condensate drain solenoid valve</li> <li>⑯ Coil for cond. drain solenoid valve</li> <li>⑰ Air Dryer Controller</li> <li>...</li> <li>⑳ Bekomat drainer</li> </ul> |
|--|--|
- ⇒ Compressed air flow direction      ⇨ Refrigerating gas flow direction

5.4. Refrigerating compressor

The refrigerating compressor is the pump in the system, gas coming from the evaporator (low pressure side) is compressed up to the condensation pressure (high pressure side). The compressors utilized are manufactured by leading manufacturers and are designed for applications where high compression ratios and wide temperature changes are present.

The hermetically sealed construction is perfectly gas tight, ensuring high-energy efficiency and long, useful life. Dumping springs support the pumping unit in order to reduce the acoustic emission and the vibration diffusion. The aspirated refrigerating gas, flowing through the coils before reaching the compression cylinders cools the electric motor. The thermal protection protects the compressor from over heating and over currents. The protection is automatically restored as soon as the nominal temperature conditions are reached.

## 5.5. Condenser

The condenser is the component in which the gas coming from the compressor is cooled down and condensed becoming a liquid. Mechanically, a serpentine copper tubing circuit (with the gas flowing inside) is encapsulated in an aluminum fin package.

The cooling operation occurs via a high efficiency fan, creating airflow within the dryer, moving air through the fin package. It's mandatory that the ambient air temperature does not exceed the nominal values. It is also important to keep the condenser unit free from dust and other impurities.

## 5.6. Filter Drier

Traces of humidity and slag can accumulate inside the refrigerating circuit. Long periods of use can also produce sludge. This can limit the lubrication efficiency of the compressor and clog the expansion valve or capillary tube. The function of the Filter Drier, located before the capillary tubing, is to eliminate any impurities from circulating through the system.

## 5.7. Capillary Tube

It consists of a piece of reduced cross section copper tubing located between the condenser and the evaporator, acting as a metering device to reduce the pressure of the refrigerant. Reduction of pressure is a design function to achieve optimum temperature reached within the evaporator: the smaller the capillary tube outlet pressure, the lower the evaporation temperature.

The length and interior diameter of the capillary tubing is accurately sized to establish the performance of the dryer; no maintenance or adjustment is necessary.

## 5.8. Alu-Dry Module

The heat exchanger module houses the air-to-air, the air-to-refrigerant heat exchangers and the demister type condensate separator. The counter flow of compressed air in the air-to-air heat exchanger ensures maximum heat transfer. The generous cross section of flow channel within the heat exchanger module leads to low velocities and reduced power requirements. The generous dimensions of the air-to-refrigerant heat exchanger plus the counter flow gas flow allows full and complete evaporation of the refrigerant (preventing liquid return to the compressor). The high efficiency condensate separator is located within the heat exchanger module. No maintenance is required and the coalescing effect results in a high degree of moisture separation.

## 5.9. Hot Gas By-pass Valve

This valve injects part of the hot gas (taken from the discharge side of the compressor) in the pipe between the evaporator and the suction side of the compressor, keeping the evaporation temperature/pressure constant at approx. 36°F (+2 °C). This injection prevents the formation of ice inside the dryer evaporator at every load condition.



### ADJUSTMENT

The Hot Gas By-pass Valve is adjusted during the manufacturing testing phase. As a rule no adjustment is required; anyway if it is necessary the operation must be carried out by an experienced refrigeration engineer.

**WARNING :** the use of 1/4" Schrader service valves must be justified by a real malfunction of the refrigeration system. Each time a pressure gauge is connected, a part of refrigerant is exhausted.

Without compressed air flow through the dryer, rotate the adjusting screw (position A on the drawing) until the following value is reached:

Hot gas setting (R134.a) :	temperature 33°F (+1 / -0 °F)
	pressure 29 psig (+1.5 / -0 psi)
	temperature 0.5°C (+0.5 / -0 °K)
	pressure 2.0 barg (+0.1 / -0 bar)

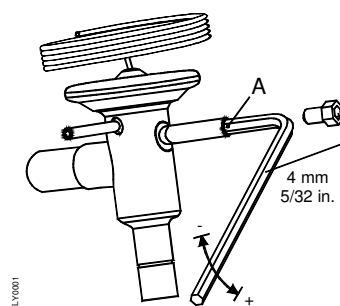

**5.10. DMC15 Electronic Instrument (Air Dryer Controller)**

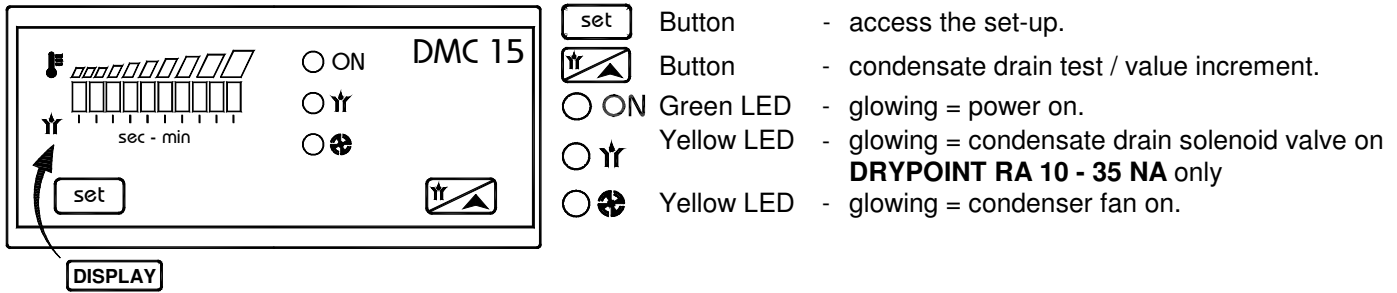

- Button - access the set-up.
- Button - condensate drain test / value increment.
- Green LED - glowing = power on.
- Yellow LED - glowing = condensate drain solenoid valve on **DRYPOINT RA 10 - 35 NA** only
- Yellow LED - glowing = condenser fan on.

The DMC15 electronic controller performs the following functions : it shows the current operating DewPoint through the digital led display which is detected from the (T1) probe located at the end of the evaporator, while a second (T2) probe, located on the discharge side of the condenser, activates the relevant fan; eventually it controls the functioning of condensate drain solenoid valve through the cyclic electronic timer (**DRYPOINT RA 10 to RA 35 NA** only).

**OPERATION - During the dryer operation, the LED ON is on.**

**Thermometer - The 10 LED display indicates the current operating DewPoint, shown by means of a two colours (green - red) bar over the display itself.**

- Green section - operating conditions ensuring an optimal DewPoint;
- Red section - DewPoint of the dryer too high, the dryer is working with elevated thermal load (high inlet air temperature, high ambient temperature, etc.). The treatment of the compressed air may be improper. Too high DewPoint temperature, value exceeding the upper limit of the instrument range, is indicated by the intermittent flashing of the last LED; whereas the intermittent flashing of the first LED shows too low DewPoint temperature. A possible (T1) probe failure is indicated by the intermittent flashing of the first and last LED of the display, whereas the dryer keeps on working correctly.

**Fan Thermo-Switch** – The fan condenser is activated when the condensate temperature reaches or exceeds 95°F (35°C) (FANON) - LED on - and it is deactivated when the temperature goes down to 86°F (30°C) (FANON - Hys) - LED off. **In case of (T2) probe failure, the fun will run continuously and the LED will intermittent flash.**

**Timer - DRYPOINT RA 10 to RA 35 NA only - The condensate drain solenoid valve is activated for 2 seconds (T<sub>ON</sub>) - LED on - each minute (T<sub>OFF</sub>), if standard setting. To perform the manual test for the condensate drain, press the button.**

**SET-UP** - The DMC15 is adjusted during the final test of the dryer. In case of particular requirements concerning the operation management, the user can change the setting of the programmed parameters.

The parameters which can be set up are the following :

- FAN<sub>ON</sub> - activation temperature of condenser fan. It is adjustable inside the following range of values, with step of 1.8°F (1 °K); whereas the Hys hysteresis is fixed and equal to -9°F (-5°K).
- **DRYPOINT RA 10 to RA 35 NA only - T<sub>ON</sub> - activation time of the condensate drain solenoid valve.**
- **DRYPOINT RA 10 to RA 35 NA only - T<sub>OFF</sub> - pause time between two consecutive activation of the condensate drain solenoid valve.**

To access the set-up, keep the button pressed for at least 2 seconds; ON LED flashing confirms the command. First appears the (FANON) parameter; to access the other parameters, press sequentially the button.

To change the value of the selected parameter, keep the button pressed and operate on button ; the current value is shown on the LED display. For the value range and the resolution (value of each single LED), see the following table :

Parameter	Description	Display	Value range	Resolution	Set value
FAN <sub>ON</sub>	Activation temperature of condenser fan	Synchronous flashing LED  + LED	(87.8 - 104 °F) (31 - 40 °C)	1.8°F 1 °K	95 °F 35°C
T <sub>ON</sub>	DRYPOINT RA 10 to RA 35 NA only Activation time of the condensate drain solenoid valve	Synchronous flashing LED  + LED	1 - 10 sec	1 sec	2 sec
T <sub>OFF</sub>	DRYPOINT RA 10 to RA 35 NA only Pause time of the condensate drain solenoid valve	Non-Synchronous flashing LED  + LED	1 - 10 min	1 min	1 min

To exit the set-up condition in any moment, press the button. If no operations are performed for 2 minutes, the system automatically exits the set-up condition.

### **5.11. Electronic level controlled condensate drain BEKOMAT**

The electronic level controlled drain BEKOMAT has a special condensate management that makes sure that condensate is drained safely without any unnecessary air-loss. This drain consists of a condensate accumulator where a capacitive sensor continuously checking liquid level is placed: as soon as the accumulator is filled, the sensor passes a signal to the electronic control and a diaphragm solenoid valve will open to discharge the condensate. Right in time the discharge line will be closed again without wasting compressed air.

**ATTENTION!**

These BEKOMAT condensate drains have been specially designed for the use in a refrigerant dryer DRYPOINT RA NA. Any Installation in other compressed air treatment units or the exchange against a different drain brand may lead to malfunction. Do not exceed the max. operating pressure (see type plate)!

**Make sure when the dryer starts the upstream valve is open.**

**NOTE:**

**For detailed information on drainer functions, troubleshooting, service and replacement parts, please refer to the BEKOMAT drainer manual.**

# 6. Maintenance, troubleshooting, spares and dismantling

## 6.1. Controls and Maintenance



### DANGER!

#### Compressed air, mains voltage, unqualified personnel!

Only qualified personnel should perform troubleshooting and or maintenance operations.

Prior to performing any maintenance or service, be sure that:

no part of the machine is powered and that it cannot be connected to the mains supply.

no part of the machine is under pressure and that it cannot be connected to the compressed air system.

Maintenance personnel have read and understand the safety and operation instructions in this manual.



Before attempting any maintenance operation on the dryer, shut it down and wait at least 30 minutes.

### DANGER!

#### Hot surfaces!



Some components can reach high temperature during operation. Avoid contact until system or component has dissipated heat.



### DAILY:

- Verify that the DewPoint displayed on the electronic instrument is correct.
- Check the proper operation of the condensate drain systems.
- Verify the condenser for cleanliness.

### EVERY 200 HOURS OR MONTHLY



MAX 2 bar / 30 Psig

With an air jet (max. 2 bar / 30 psig) blowing from inside towards outside clean the condenser; repeat this operation blowing in the opposite way; be careful not to damage the aluminium fins of the cooling package.



- **DRYPOINT RA 10 to RA 35 NA only** -Close the isolation valve for the condensate drain, remove the mechanical filter and clean it with compressed air and a brush. Reinstall the filter, make sure it is secure, and open the isolation valve.

- At the end, check the operation of the machine.



### EVERY 1000 HOURS OR YEARLY

- Verify for tightness all the screws of the electric system and that all the "Faston" type connections are in their proper position, inspect unit for broken, cracked or bare wires.
- Inspect refrigerating circuit for signs of oil and refrigerant leakage.
- Measure and record amperage. Verify that readings are within acceptable parameters as listed in specification table.
- Inspect condensate drain flexible hoses, and replace if necessary.
- At the end, check the operation of the machine.

## 6.2. Troubleshooting



Only qualified personnel should perform troubleshooting and or maintenance operations. Prior to performing any maintenance or service, be sure that:

- no part of the machine is powered and that it cannot be connected to the mains supply.
- no part of the machine is under pressure and that it cannot be connected to the compressed air system.
- Maintenance personnel have read and understand the safety and operation instructions in this manual.



Before attempting any maintenance operation on the dryer, shut it down and wait at least 30 minutes. Some components can reach high temperature during operation. Avoid contact until system or component has dissipated heat



### SYMPTOM

### POSSIBLE CAUSE - SUGGESTED ACTION

◆ The dryer doesn't start.	⇒ Verify that the system is powered. ⇒ Verify the electric wiring.
◆ The compressor doesn't work.	⇒ Activation of the compressor internal thermal protection - wait for 30 minutes, then retry. ⇒ Verify the electric wiring. ⇒ <b>Where installed-</b> Replace the internal thermal protection and/or the start-up relay and/or the start-up capacitor and/or the working capacitor. ⇒ If the compressor still doesn't work, replace it.
◆ The fan of the condenser doesn't work.	⇒ Verify the electric wiring. ⇒ The DMC15 electronic controller is faulty - replace it. ⇒ If the fan still doesn't work, replace it.
◆ DewPoint too low.	⇒ The fan is always ON - the  yellow LED of DMC15 controller is glowing continuously - see specific point. ⇒ Ambient temperature is too low - restore de nominal condition. ⇒ The Hot Gas By-pass Valve is out of setting - contact a refrigeration engineer to restore the nominal setting.
◆ DewPoint too high.	⇒ The dryer doesn't start - see specific point. ⇒ The T1 DewPoint probe doesn't correctly detect the temperature - ensure the sensor is pushed into the bottom of copper tube immersion well. ⇒ The refrigerating compressor doesn't work - see specific point. ⇒ The ambient temperature is too high or the room aeration is insufficient - provide proper ventilation. ⇒ The inlet air is too hot - restore the nominal conditions. ⇒ The inlet air pressure is too low - restore the nominal conditions. ⇒ The inlet air flow rate is higher than the rate of the dryer - reduce the flow rate - restore the normal conditions. ⇒ The condenser is dirty - clean it. ⇒ The condenser fan doesn't work - see specific point. ⇒ The dryer doesn't drain the condensate - see specific point. ⇒ The Hot Gas By-pass Valve is out of setting - contact a refrigeration engineer to restore the nominal setting. ⇒ There is a leak in the refrigerating fluid circuit - contact a refrigeration engineer.
◆ Excessive pressure drop within the dryer.	⇒ The dryer doesn't drain the condensate - see specific point. ⇒ The DewPoint is too low - the condensate is frost and blocks the air - see specific point. ⇒ Check for throttling the flexible connection hoses.
◆ <b>DRYPOINT RA 10 - 35 NA</b> The dryer doesn't drain the condensate.	⇒ The condensate drain service valve is closed - open it. ⇒ The condensate drain strainer is clogged - remove and clean it. ⇒ The drain solenoid valve is jammed - remove and clean it. ⇒ Verify the electric wiring. ⇒ The coil of the condensate drain solenoid valve burned out - replace it. ⇒ The DewPoint is too low - the condensate is frozen - see specific point.

## Maintenance, troubleshooting, spares and dismantling

---

◆ <b>DRYPOINT RA 50 - 100 NA</b> The dryer doesn't drain the condensate.	⇒ The condensate drain service valve is closed - open it. ⇒ Verify the electric wiring. ⇒ The DewPoint is too low - the condensate is frozen - see specific point. ⇒ Bekomat drainer is not operating correctly – (see BEKOMAT MANUAL).
◆ <b>DRYPOINT RA 10 - 35 NA</b> The dryer continuously drains condensate.	⇒ The drain solenoid valve is jammed - remove and clean it. ⇒ Try to remove the electric connector on the solenoid valve - if drain stops verify the electric wiring or the electronic instrument is faulty - replace it.
◆ <b>DRYPOINT RA 50 - 100 NA</b> The dryer continuously drains condensate.	⇒ Bekomat drainer is not operating correctly (see BEKOMAT MANUAL). ⇒ Bekomat drainer is dirty (see BEKOMAT MANUAL).
◆ Water within the line.	⇒ The dryer doesn't start - see specific point. ⇒ Where installed - Untreated air flows through the by-pass unit - close the by-pass. ⇒ The dryer doesn't drain the condensate - see specific point. ⇒ DewPoint too high - see specific point.
◆ <b>DMC15-</b> The first and the last LED of the display of electronic instrument blink simultaneously.	⇒ Verify the electric wiring of (T1) DewPoint probe. ⇒ The (T1) DewPoint probe is faulty - replace it. ⇒ The DMC15 electronic controller is faulty - replace it.
◆ <b>DMC15-</b> The  yellow LED of the electronic controller is flashing continuously.	⇒ Verify the electric wiring of (T2) fan control probe. ⇒ The (T2) fan control probe is faulty - replace it. ⇒ The DMC15 electronic controller is faulty - replace it.
◆ <b>DMC15-</b> The first LED of the display of electronic instrument is flashing continuously.	⇒ DewPoint too low - see specific point. ⇒ The (T1) DewPoint probe is faulty - replace it. ⇒ The DMC15 electronic controller is faulty - replace it.
◆ <b>DMC15-</b> The last LED of the display of electronic instrument is flashing continuously.	⇒ DewPoint too high - see specific point. ⇒ The (T1) DewPoint probe is faulty - replace it. ⇒ The DMC15 electronic controller is faulty - replace it.

---

### 6.3. Spare Parts

The suggested spare parts list will enable you to promptly intervene in case of abnormal operation, so avoiding to wait for the spares delivery. In case of failure of other parts, for example inside the refrigerating circuit, the replacement must be worked out by a refrigerating systems specialist or in our factory.

**NOTE: To order the suggested spare parts or any other part, it's necessary to quote the data reported on the data nameplate.**

N.	DESCRIPTION OF THE SPARE PARTS	CODE	DRYPOINT RA NA – P (115/1/60)							DRYPOINT RA NA – E (230/1/60)							
			10	15	20	35	50	75	100	10	15	20	35	50	75	100	
6	Compressor	XERA 5015 110 101								1	1	1					
6	Compressor	XERA 5015 110 107										1	1				
6	Compressor	XERA 5015 110 115												1			
6	Compressor	XERA 5015 115 011															1
6	Compressor	XERA 5015 135 101	1	1	1												
6	Compressor	XERA 5015 135 103				1											
6	Compressor	XERA 5015 135 105					1										
6	Compressor	XERA 5015 135 010						1									
6	Compressor	XERA 5015 135 011														1	
8	Hot gas by-pass valve	XERA 6414 OSS 160	1	1	1	1	1	1	1	1	1	1	1	1	1	1	1
9.1	Fan motor	XERA 5210 110 005								1	1	1					
9.1	Fan motor	XERA 5210 110 011															1
9.1	Fan motor	XERA 5210 110 017															1
9.1	Fan motor	XERA 5210 135 005	1	1	1	1											
9.1	Fan motor	XERA 5210 135 010					1	1									
9.1	Fan motor	XERA 5210 135 015															1
9.2	Fan blade	XERA 5215 000 010	1	1	1	1				1	1	1					
9.2	Fan blade	XERA 5215 000 019					1	1					1	1			
9.2	Fan blade	XERA 5215 000 022															1
9.3	Fan guard	XERA 5225 000 010										1	1				1
10	Filter Drier	XERA 6650 SSS 007	1	1	1	1	1	1	1	1	1	1	1	1	1	1	1
12	DewPoint probe T1 DMC15	XERA 5625 NNN 033	1	1	1	1	1	1	1	1	1	1	1	1	1	1	1
12.1	DewPoint probe T2 DMC15	XERA 5625 NNN 035	1	1	1	1	1	1	1	1	1	1	1	1	1	1	1
13+14	Condensate drain valve/strainer	XERA 6435 5MN 012	1	1	1	1											
15	Condensate drain solenoid valve	XERA 6432 OFF 080													1	1	
15	Condensate drain solenoid valve	XERA 6432 OFF 081	1	1	1	1											
16	Coil for cond. drain solenoid valve	XERA 64N2 2MM 001													1	1	
16	Coil for cond. drain solenoid valve	XERA 64N2 2MM 002	1	1	1	1											
17	DMC15 Controller 230V	XERA 5620 110 104													1	1	1
17	DMC15 Controller 115V	XERA 5620 130 104	1	1	1	1	1	1	1	1	1	1	1	1	1	1	1
21	BEKOMAT 31	BM31 BI (supply voltage)															
22	Main switch	XERA 5450 SZN 010	1	1	1	1	1	1	1	1	1	1	1	1	1	1	1

◆ Suggested spare part.

## 6.4. Maintenance operation on the refrigerating circuit



### CAUTION! Refrigerant fluid!

Maintenance and service on refrigerating systems must be carried out only by certified refrigerating engineers only, according to local rules.

All the refrigerant of the system must be recovered for its recycling, reclamation or destruction.

**Do not dispose the refrigerant fluid in the environment.**

This dryer comes ready to operate and filled with R134a or R404A type refrigerant fluid.



In case of refrigerant leak contact a certified refrigerating engineers. Room is to be aired before any intervention.

If is required to re-fill the refrigerating circuit, contact a certified refrigerating engineers.

Refer to the dryer nameplate for refrigerant type and quantity.

Characteristics of refrigerants used:

Refrigerant	Chemical formula	TLV	GWP
R134a - HFC	CH <sub>2</sub> FCF <sub>3</sub>	1000 ppm	1300
R404A - HFC	CH <sub>2</sub> FCF <sub>3</sub> /C <sub>2</sub> HF <sub>5</sub> /C <sub>2</sub> H <sub>3</sub> F <sub>3</sub>	1000 ppm	3784

## 6.5. Dismantling of the Dryer

If the dryer is to be dismantled, it has to be split into homogeneous groups of materials.



Part	Material
Refrigerant fluid	R404A, R134a, Oil
Canopy and Supports	Carbon steel, Epoxy paint
Refrigerating compressor	Steel, Copper, Aluminium, Oil
Alu-Dry Module	Aluminium
Condenser Unit	Aluminium, Copper, Carbon steel
Pipe	Copper
Fan	Aluminium, Copper, Steel
Valve	Brass, Steel
Electronic Level Drain	PVC, Aluminium, Steel
Insulation Material	Synthetic gum without CFC, Polystyrene, Polyurethane
Electric cable	Copper, PVC
Electric Parts	PVC, Copper, Brass



We recommend to comply with the safety rules in force for the disposal of each type of material.

The chilling fluid contains droplets of lubrication oil released by the refrigerating compressor.

Do not dispose this fluid in the environment. It has to be discharged from the dryer with a suitable device and then delivered to a collection centre where it will be processed to make it reusable.

## 7. List of attachments

### 7.1. Dryers Dimensions

#### 7.1.1. Dryers Dimensions DRYPOINT RA 10-15 NA

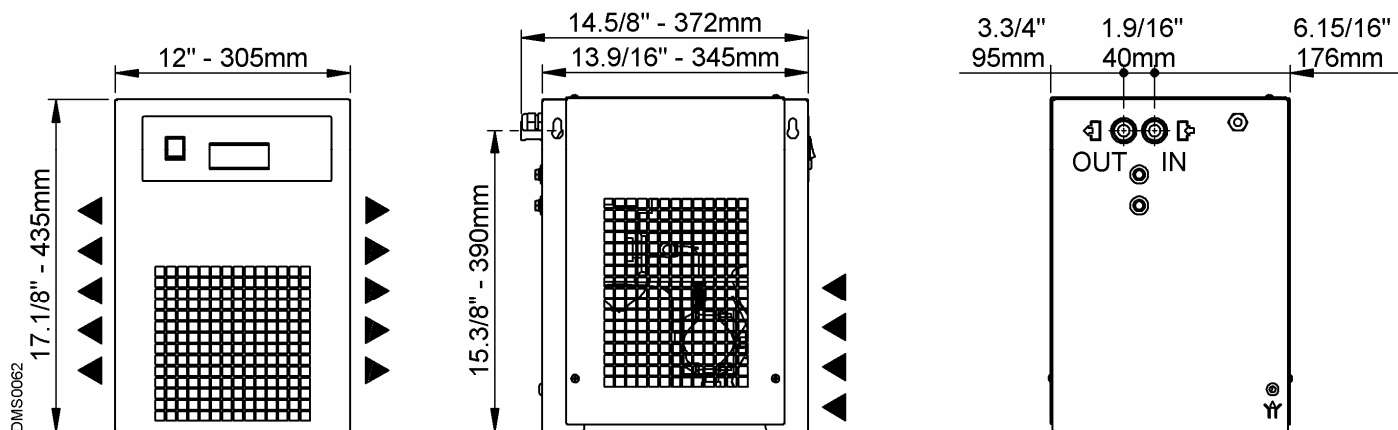

#### 7.1.2. Dryers Dimensions DRYPOINT RA 20-50 NA

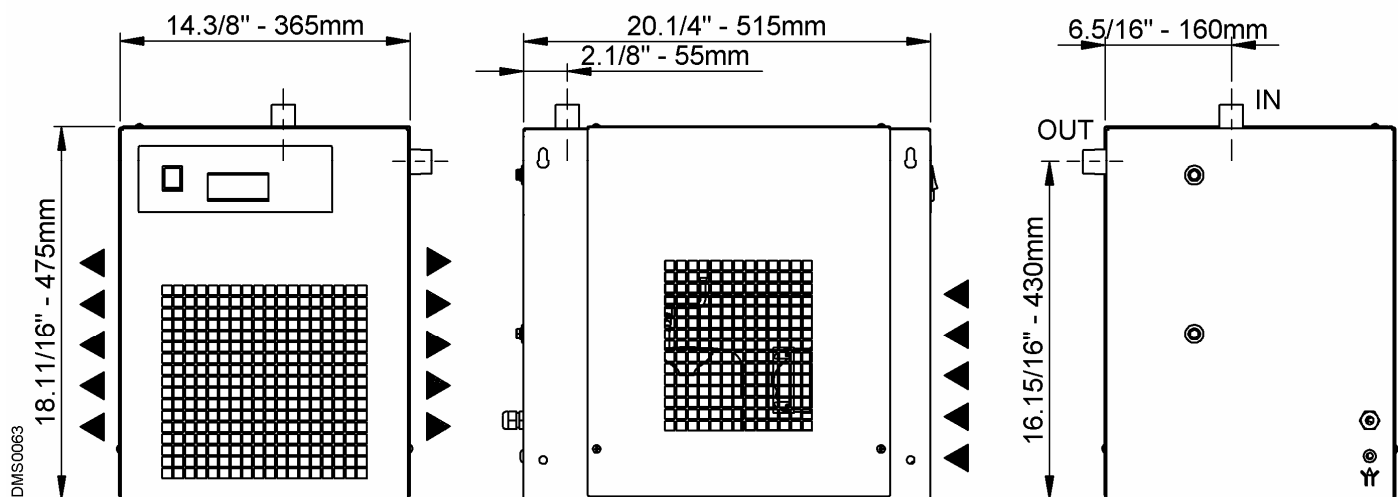

## List of attachments

### 7.1.3. Dryers Dimensions DRYPOINT RA 75 NA

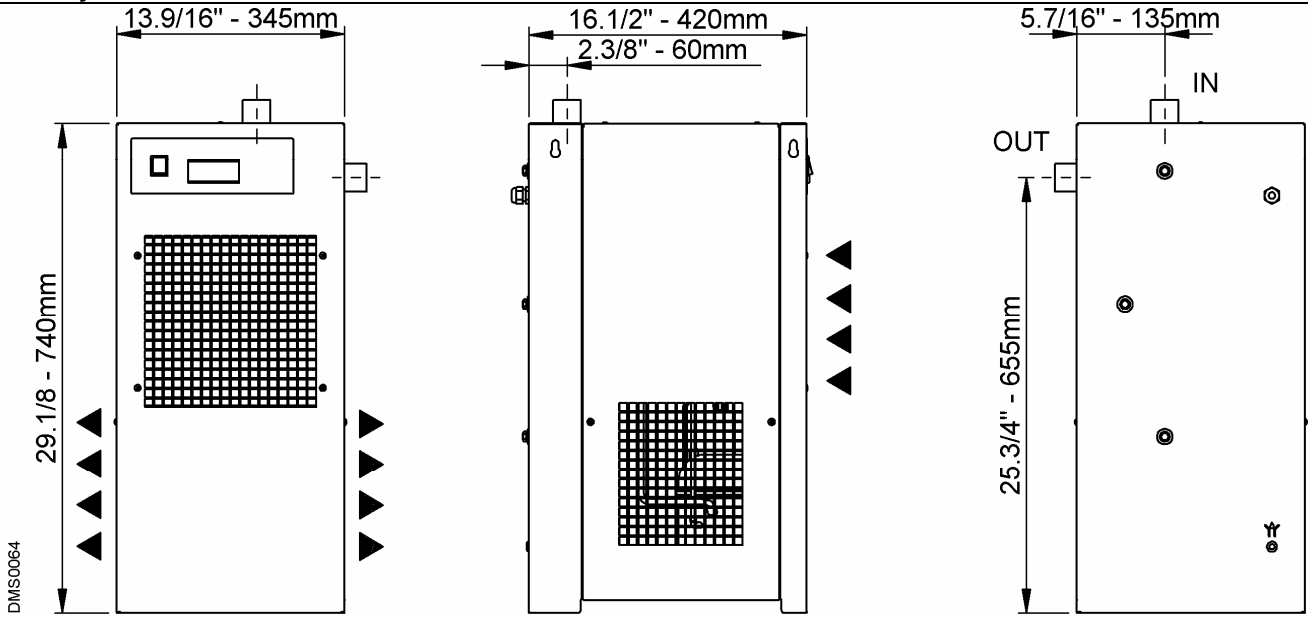

### 7.1.4. Dryers Dimensions DRYPOINT RA 100 NA

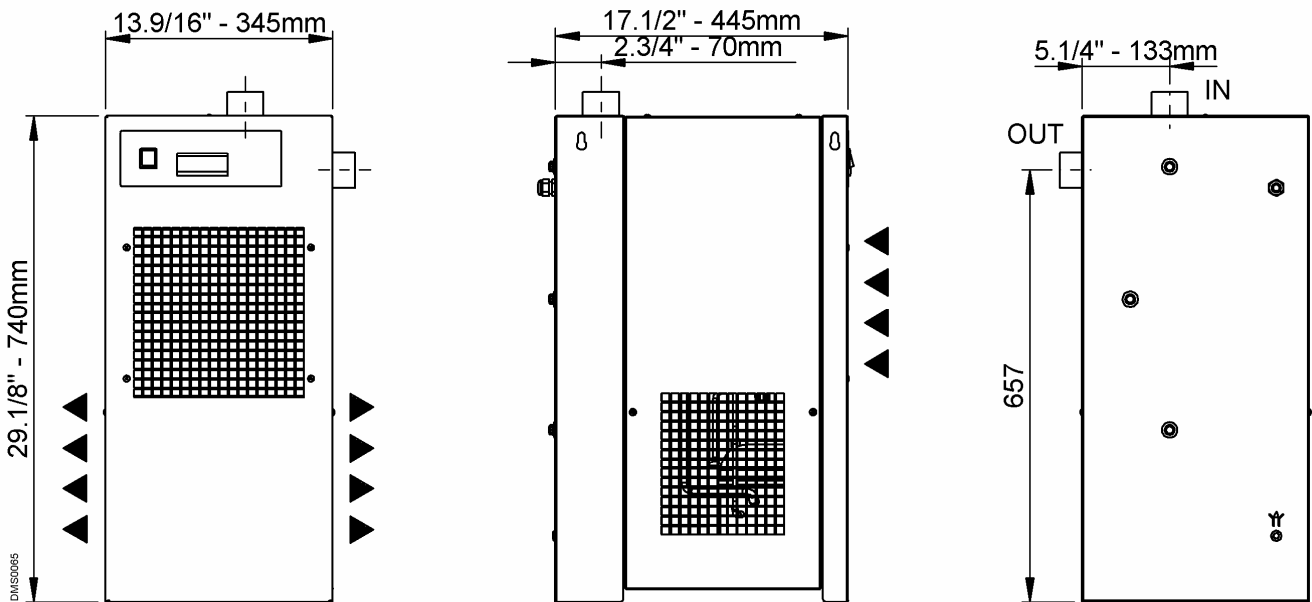

## 7.2. Exploded View

### 7.2.1. Exploded view table of components DRYPOINT RA 10-100 NA

① Alu-Dry Module	⑩ Coil for cond. drain solenoid valve
1.1 Insulation Material	⑪ Electronic control instrument
...	...
⑥ Refrigerating compressor	⑫ Bekomat drainer
⑦ Hot Gas By-pass Valve	⑬ Main switch
⑧ Condenser (Air-Cooled)	...
⑨ Condenser fan	⑭ Front panel
9.1 Motor	⑮ Back panel
9.2 Blade	⑯ Right lateral panel
9.3 Grid	⑰ Left lateral panel
⑩ Filter Drier	...
⑪ Capillary tube	⑱ Base plate
⑫ T1 Temperature probe (DewPoint)	...
⑬ Condensate drain service valve	⑲ Support bracket
⑭ Y-shaped condensate drain strainer	...
⑮ Condensate drain solenoid valve	⑳ Electric connector

# List of attachments

## 7.2.2. Exploded view DRYPOINT RA 10-15 NA

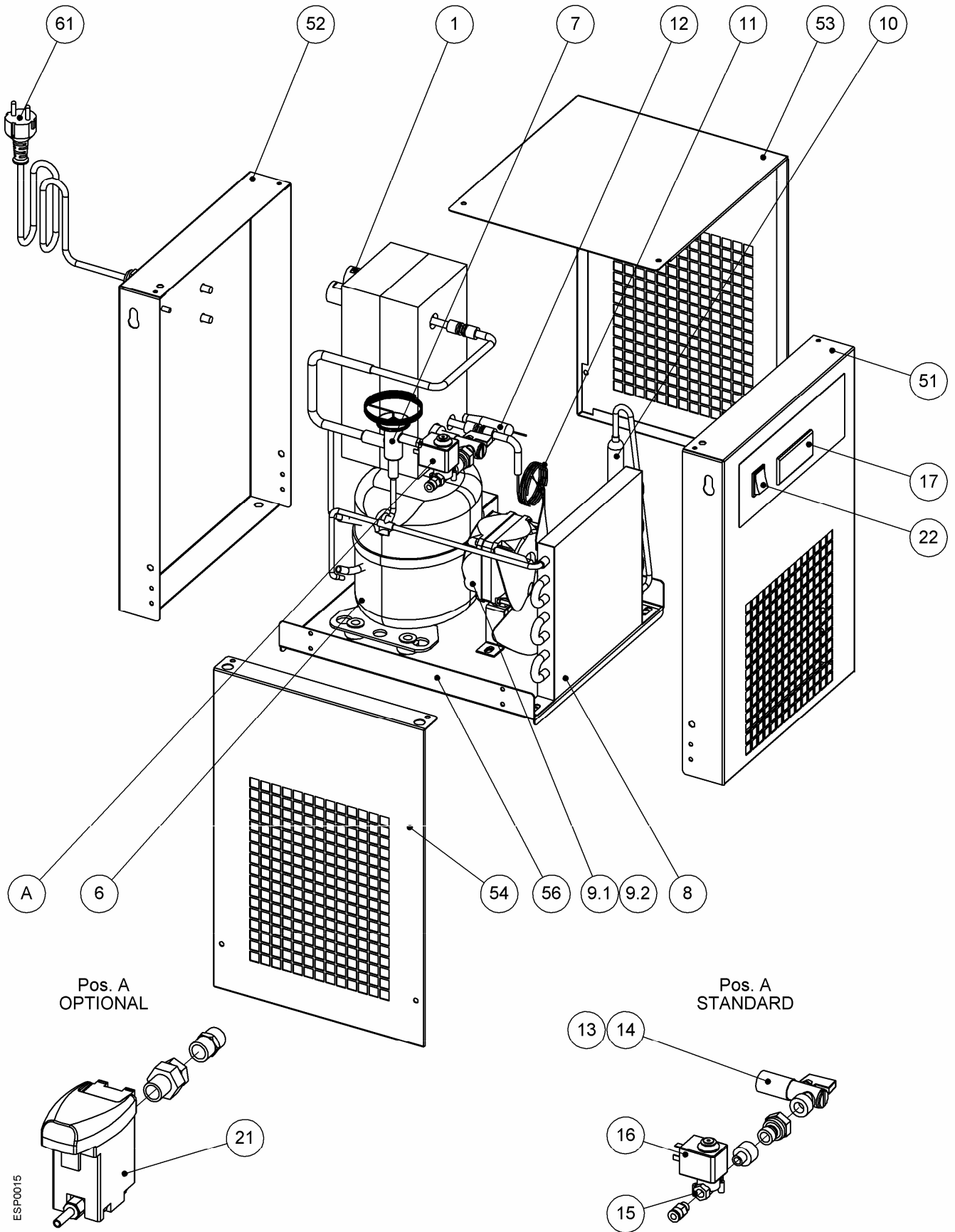

7.2.3. Exploded view DRYPOINT RA 20-35 NA

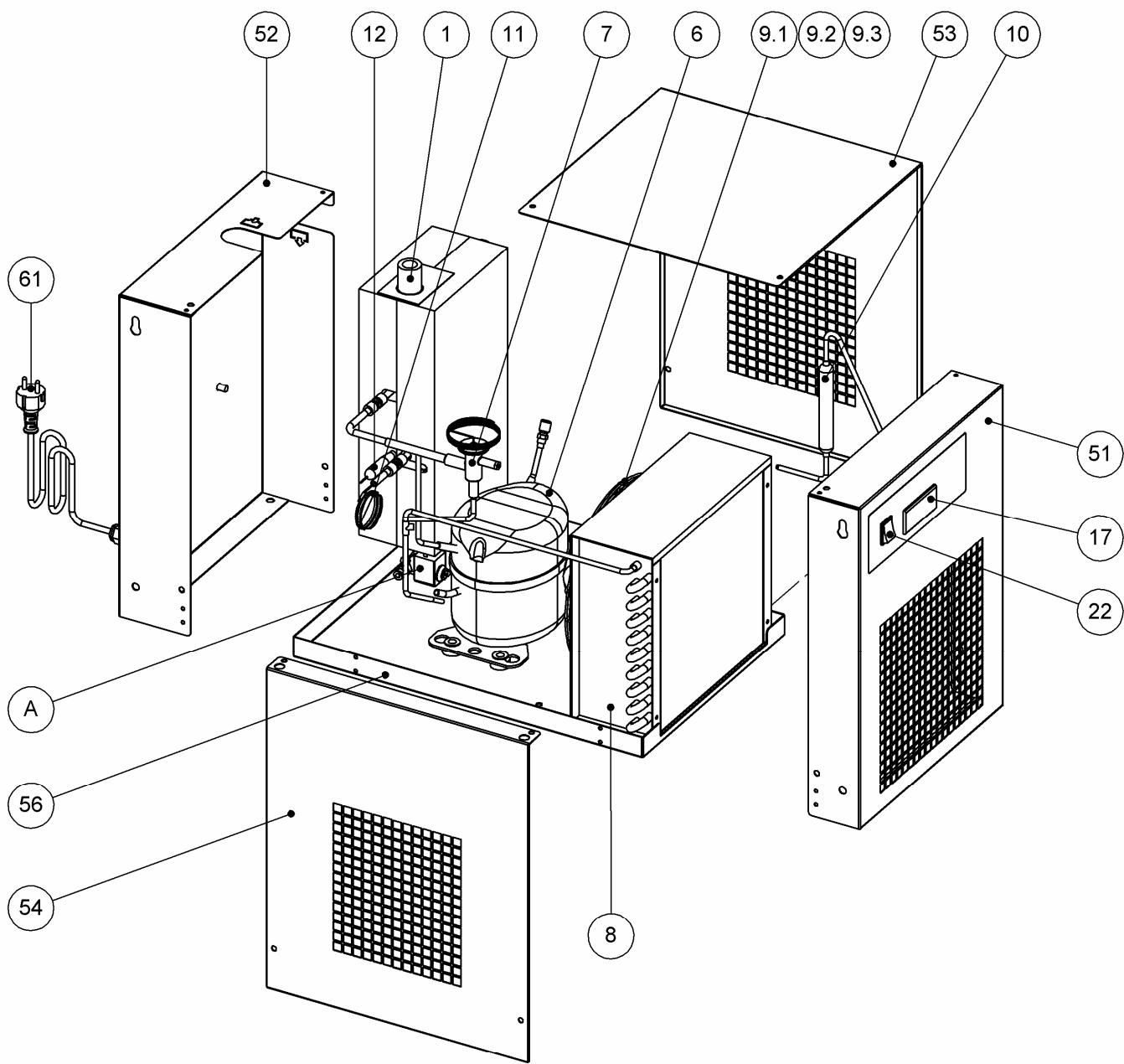

Pos. A  
OPTIONAL

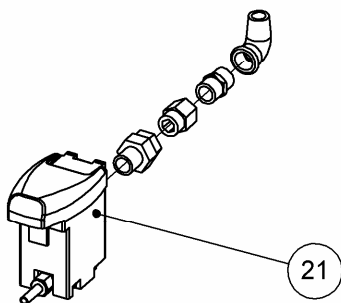

ESP0011

Pos. A  
STANDARD

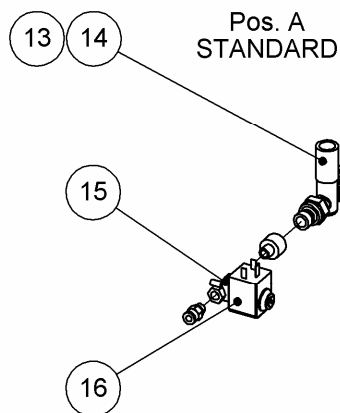

# List of attachments

## 7.2.4. Exploded view DRYPOINT RA 50 NA

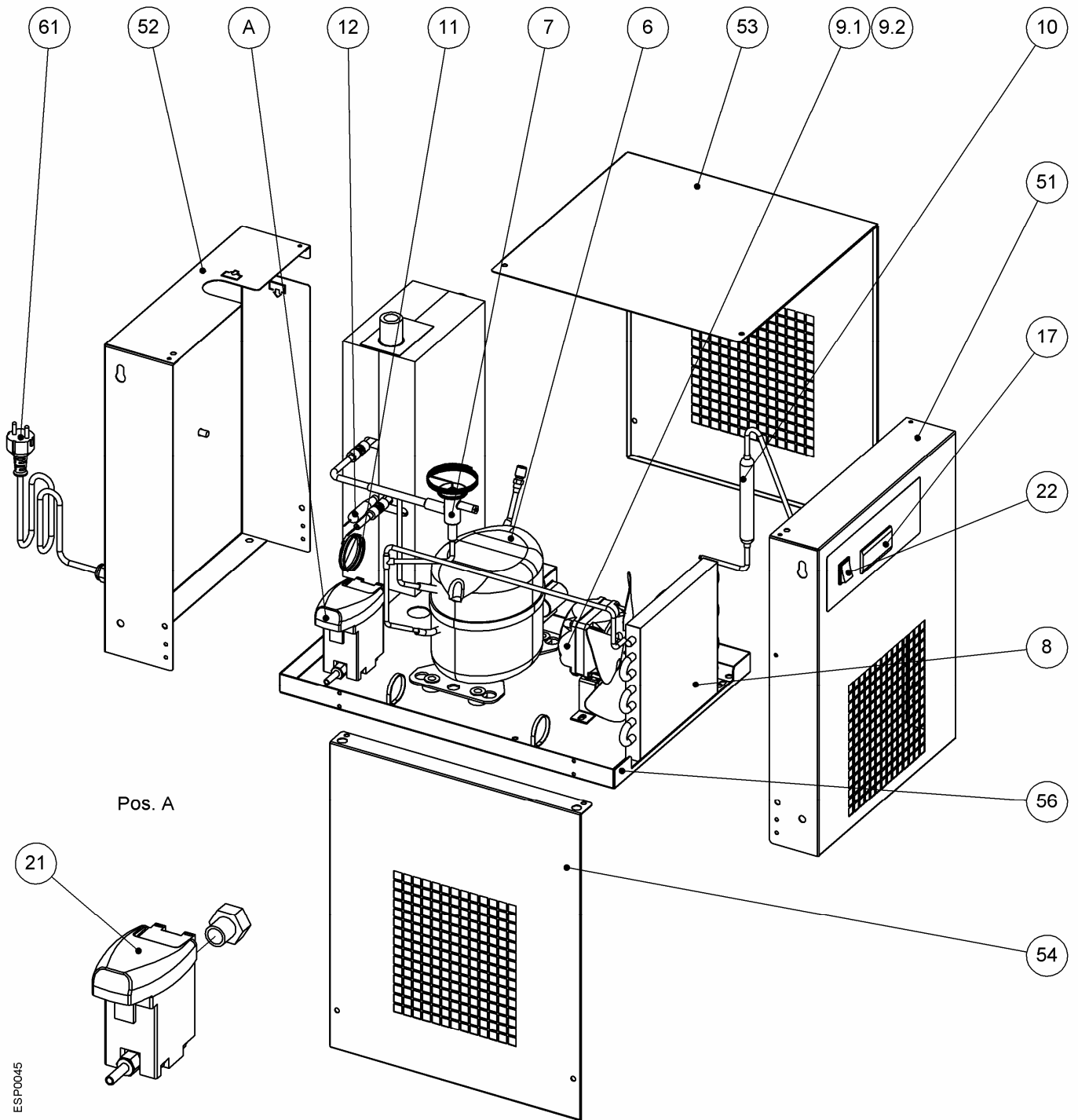

ESP0045

7.2.5. Exploded view DRYPOINT RA 75-100 NA

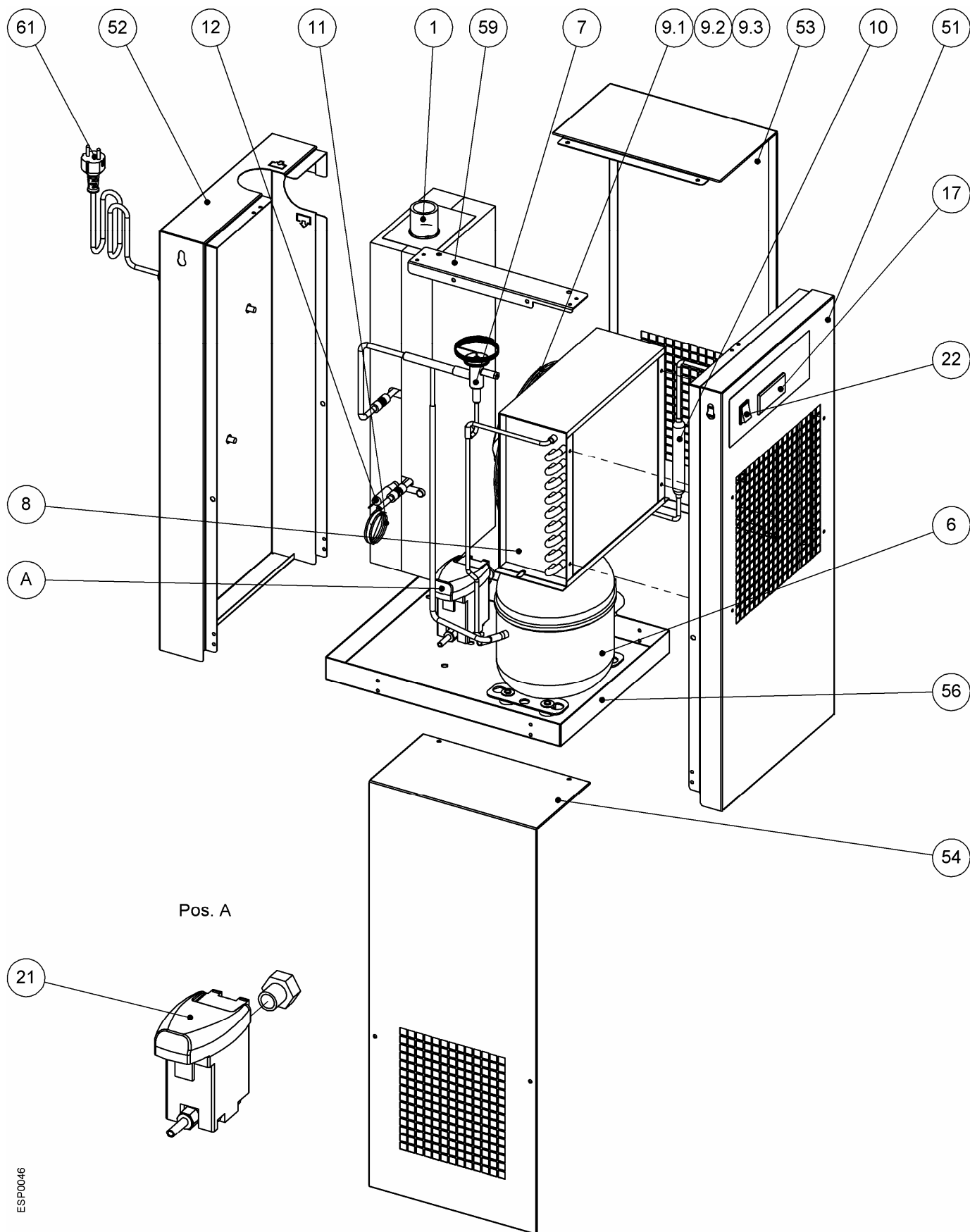

ESP0046

### 7.3. Electrical Diagram

#### 7.3.1. Electrical Diagram table of components

<b>IG</b>	: Main switch
<b>K</b>	: Refrigerating compressor
<b>KT</b>	: Compressor thermal protection
<b>KR</b>	: Compressor starting relay (if installed)
<b>CS</b>	: Compressor starting capacitor (if installed)
<b>CR</b>	: Compressor run capacitor (if installed)
<b>V</b>	: Condenser fan
<b>CV</b>	: Fan starting capacitor (if installed)
<b>DMC15</b>	: DMC15 Electronic Instrument - Air Dryer Controller
<b>T1</b>	: T1 Temperature probe (DewPoint)
<b>T2</b>	: T2 Temperature probe (Fan control)
<b>EVD</b>	: Condensate drain solenoid valve (DRYPOINT RA 10-35 NA)
<b>ELD</b>	: Bekomat drainer (DRYPOINT RA 50 - 100 NA)
	BN = BROWN
	BU = BLUE
	BK = BLACK
	YG = YELLOW/GREEN

7.3.2. Electrical Diagram DRYPOINT RA 10-100 NA -P (115/1/60)

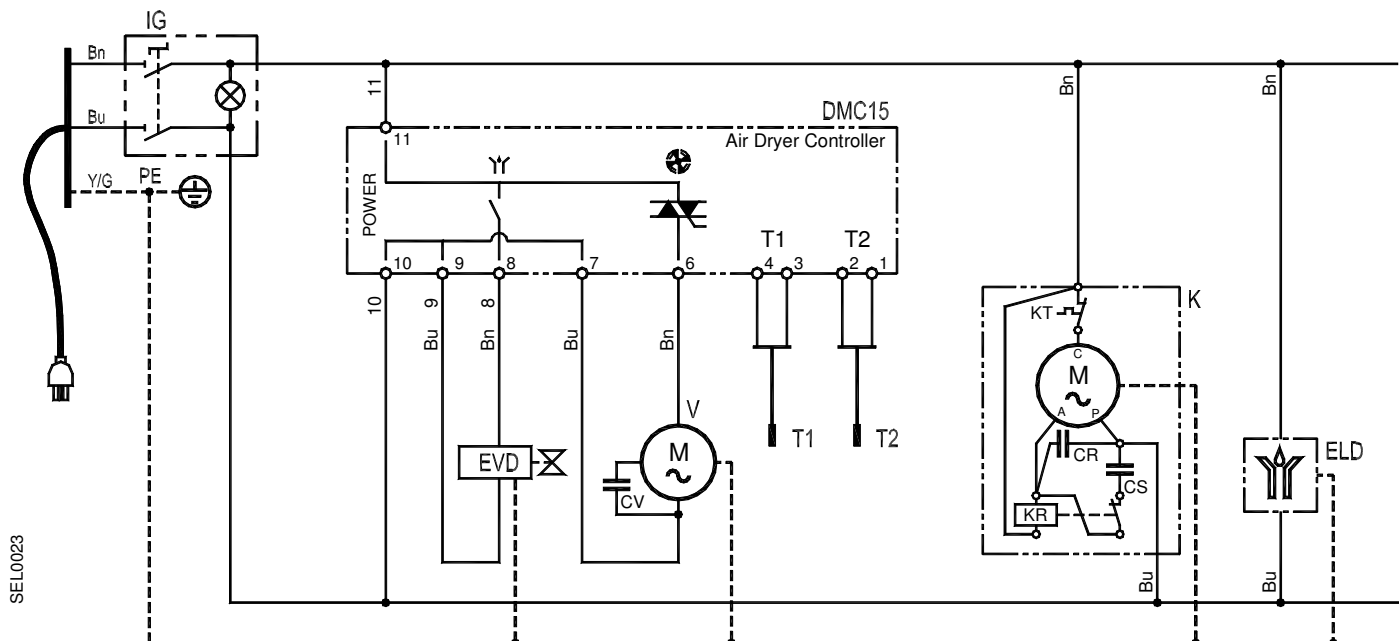

7.3.3. Electrical Diagram DRYPOINT RA 10-100 NA -P (230/1/60)

